

SuperGuard & Piguard *plus* 80/81/82

HOG CONTROLLER SYSTEM



User/Installer Manual

CONTENTS

TOPIC	PAGE #
<u>GENERAL</u>	4
SUPPORT INFORMATION	4
EXPLANATION OF SYMBOLS AND MANUAL ELEMENTS.....	4
INTRODUCTION.....	5
COMPONENTS	5
GENERAL DESCRIPTION	6
FEATURES	7
<u>GETTING STARTED</u>	8
5 STEP INSTALLATION GUIDE	8
SUPERGUARD KEYBOARD.....	9
SUPERGUARD MAIN-SCREEN	10
HOTKEYS	12
SUPERGUARD SETUP	15
SETTING TABLES	17
<u>1 CONTROL</u>	18
1.1 TEMP CURVE	18
1.2 HUMIDITY	18
1.3 MIN. VENT. TIMER	19
1.4 MIN VENT POS.....	19
1.5 STATIC PRESSURE.....	20
1.6 WIND PROGRAM.....	21
1.7 SYSTEM PARAMETERS	21
<u>2 DEVICE</u>	22
2.1 TEMP SETTING.....	22
2.2 CURTAIN	23
2.3 COOL CELL.....	24
2.4 FOGGERS	25
2.5 LIGHT	25
2.6 FEED.....	25
2.7 EXTRA SYSTEM	26
<u>3 MANAGEMENT</u>	26
3.1 ANIMAL INVENTORY	26
3.2 DAY & GROUP	26
3.3 ALARM SETTING	27
3.4 ALARM RESET	28
3.5 PASSWORD.....	28
<u>4 HISTORY</u>	28
4.1 TEMPERATURE.....	28
4.2 HUMIDITY	28
4.3 WATER	29
4.4 FEED.....	29
4.5 MORTALITY	29

4.6 HEATER	29
4.7 ALARM.....	30
4.8 EVENT	31
5 SERVICE	31
5.1 TEMP CALIBRATION	31
5.2 HUMIDITY CALIBRATION	31
5.3 PRESSURE CALIBRATION.....	31
5.4 ANALOG OUTPUT.....	32
5.5 WATER & FEED.....	32
5.6 VERSION	32
5.7 READ PLUG	32
5.8 WRITE PLUG	32
6 INSTALLATION	33
6.1 RELAY LAYOUT.....	33
6.2 SENSORS	33
6.3 DIGITAL INPUT.....	34
6.4 ANALOG OUTPUT	34
6.5 VARIABLE SPEED FAN.....	34
6.6 SENSOR DEFINITION.....	35
6.7 CURTAIN SETUP	35
PIGUARD PLUSES	36
COLD START	36
SET UNIT NUMBER.....	36
MAIN MENU	36
CALIBRATION.....	36
TEST.....	37
TECHNICAL SPECIFICATIONS.....	38
PIGUARD PLUS INSTALLATION GUIDE.....	39
MECHANICAL INSTALLATION GUIDE.....	40
METAL SHEET ASSEMBLY DIAGRAM.....	41
SUPERGUARD/PIGUARD PLUS NETWORK CONNECTION	42
PIGUARD PLUS WIRING DIAGRAM.....	42
PIGUARD PLUS WIRING DIAGRAM.....	43
PIGUARD PLUS WIRING DIAGRAM.....	44

General

Thank you for purchasing a Rotem SuperGuard/Piguard Plus hog controller system. This manual will help you get the most out of your new Rotem controller. Please read the manual before installing and configuring your SuperGuard/Piguard Plus system.

Support Information

Using this equipment for any other purpose or in a way not within the operating recommendations specified in this manual will void the warranty and may cause personal injury.

Explanation of Symbols and Manual Elements

 **caution !** → *Cautions alert you to potential damage to the controller, if the procedures are not followed carefully.*

 **! DANGER !** → *Dangers alert you to potentially hazardous situations which, if not avoided could result in death or personal injury.*

*** <Note>** *Notes contain important "tips" and additional information you should know.*

Distributor and Installer Information

Please fill in the following information about your Product.
Keep this manual in a clean, dry place for future reference.

Distributor's Name	_____
Distributor's Address	_____
Distributor's E-mail	_____ @ _____
Distributor's Phone	_____
Date of Purchase	_____
Installer's Name	_____
Installer's Address	_____
Installer's E-mail	_____ @ _____
Installer's Phone	_____
Date of Installation	_____
System Specifications	_____

Introduction

This manual provides easy to use information for installation, operation, long/short term planning and parts listing. The table of contents is an outline of the relevant information in this manual.

Read this manual before operating your Rotem Controller.

If you have any questions or comments regarding your controller please contact your local Rotem dealer.

Components

- SuperGuard
- Piguard Plus
- Mux 485 Communicator (optional)
- Extension Box (optional)

General Description

SuperGuard

The ultimate in pig confinement controllers, provides you maximum capability with minimal complication in programming up to ten Piguard Plus room controllers. Equipped with an easy programming interface and 4x20 line LCD screen enables efficient access to the relevant information. The SuperGuard, also referred to by ROTEM designers as the Piguard Plus server, functions as a server to up to ten Piguard Pluses. It maintains extensive history logs for as much as 100 days. In addition, the user-friendly SuperGuard features a real time clock, a data plug for quick program transfer, plus multi lingual support.

Piguard Plus

ROTEM's latest breakthrough in environmental controllers, especially designed for the pig confinement industry. Piguard Plus satisfies the environmental requirements by optimizing control between input and output. Integrated into each controller are accurate inputs for temperature and humidity, seven output relays and four analog outputs for variable speed fans.

Every Piguard can be programmed differently through the SuperGuard and sustain different accessories or ventilation options according to the farmer's needs.

Each Piguard can operate independently, in case of SuperGuard malfunction or loss of power. Using an internal battery... when the Piguard is operating "alone", there is no history collection or possibility to change parameters.

Features

SuperGuard

- ❖ Easy programming
- ❖ LCD - 4x20 characters
- ❖ Positioning scrollbar
- ❖ Swift device and feature selection
- ❖ Data plug
- ❖ Large numeric keypad
- ❖ Built in EMI Filter.
- ❖ Communication with up to ten Piguard Plus units.
- ❖ Extensive memory of events & alarms
- ❖ Real time visual outlook
- ❖ Alarm system (for every Piguard Plus unit)
- ❖ Multi language Support.
- ❖ PC communication

Piguard Plus

- ❖ Easy programming
- ❖ Programmable outputs
- ❖ Alarm system
- ❖ Large digital display
- ❖ Up to four temperature sensors
- ❖ 8 (+8) Output Relays
 - 30 Amps 115-230 Volt.
 - 8 Relay Extension Box Connection
- ❖ Extensive Historical and Management Information Collection
- ❖ Integrated Static Pressure (Optional by Request)
- ❖ Alarm Relay
- ❖ 3 Digital inputs
- ❖ 2 Analog inputs (Potentiometer, other)
- ❖ 4 0-10V Analog Outputs
- ❖ Build in 4 Amp Variable Speed with Override 2 HP 30 Amp Relay
- ❖ Variable Speed Auto/Manual Override Switch.
- ❖ Plug in RS-485 Communication card with Lightning protection.
- ❖ Power Supply input build In EMI Filter and Lightning Protection
- ❖ Precision Control, Ventilation, Cooling, Heating, and Humidity treatment.

Getting Started

5 Step Installation Guide

This is a quick **5 step** guide that will help you figure out the order of actions for a proper system installation:

1. **Hardware Installation**: Read all technical specs' and use the wiring diagrams, from 38 on this manual, to properly install all hardware.
2. **Piguard Plus Cold Start**: Plug in the controller and hold its three keys simultaneously for a few seconds until a CLD sign will appear.
3. **Piguard Plus Unit Number**: press the two arrow keys together until the number sign (NO.) blinks. Select the unit number with the up and down arrows and press Select.
4. **Super Guard cold start**: Plug in the controller and hold the delete key (DEL) for a few seconds until a Cold Start sign will appear.
5. **Super Guard setup (Room #0)**: Follow the instructions on page 16.

***<Note>** Before making any changes make sure you are changing the correct room by checking the room number on the upper right side of the screen.

6. **Super Guard Installation**: Follow the instructions from page 34. If you have more then one room, don't forget to change room number and install the rest.
7. **Super Guard Service**: Calibrate your equipment on each room using the service menu.
8. **Super Guard Control**: Follow the instructions from page 19 regarding the control parameters for each room.
9. **Super Guard Device**: Follow the instructions from page 23 regarding the device settings for each room/
10. **Super Guard Management**: Follow the instructions from page 27 regarding live stock and alarm management for each room.

The History menu is for viewing purposes only.

SuperGuard Keyboard



Keyboard Functions

A	Menu	Toggles the menu function
B	Room	The room key is used to switch between rooms. Press the room key and press a number to reach the desired room.
C	Arrows	Use the arrows to scroll a short press in any direction moves one notch. A long press will "fast forward" to the end.
D	Round Arrows	The Round Arrows key is a used to scroll between options (Yes/No, On/Off etc).
E	Enter	The enter key is a confirmation key.
F	Numeric Pad	
G	Delete	

SuperGuard Main-screen

TEMP	27.1	ROOM	#01
TRGT	24.0	DAY	1
RH%	75.0	Hr.	13:21
RH%T	80.0	LEVEL	1

***<Note>** The main screen shows basic information regarding rooms controlled by the SuperGuard, depending on what equipment is plugged in.

TEMP	Current room temperature
TRGT	Target temperature
RH%	Current room humidity
RH%T	Target humidity
03:53 #01	Clock time and room number
DAY	Growth day
SPD1/2 %	Ventilation percentage (Variable speed fan). 1 – for PG81, 2 – for PG82.
MIN VENT	Ventilation mode (Fan/Natural/Tunnel)
OUT	Outside Temp.



In case of an alarm, a blinking message will appear on any one of the main screens in addition to the siren. Pressing "0" on the main screen, when the alarm message is on, will direct you to the source of the problem. Resetting the alarm is possible, but it only stops the siren and not the screen message. Only by fixing the problem will the message stop.

Pressing the zero on the numeric pad, while the alarm is activated will open the room status screen.

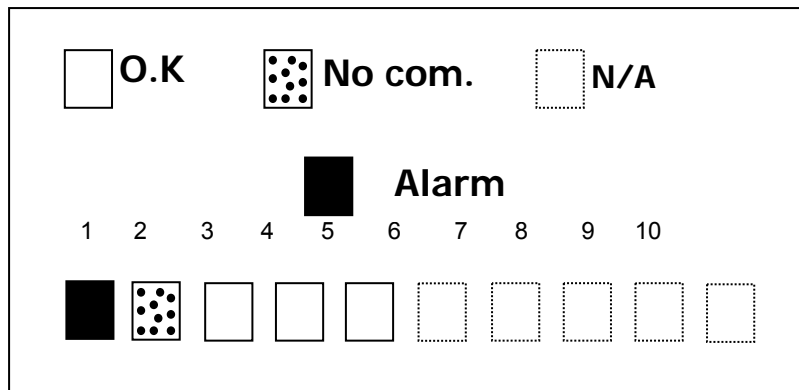

- ▶ A filled square indicates an alarm is on.
- ▶ A dotted square indicates that there is no communication with the **Piguard Plus**.

***<Note>** ▪ Once communication is off there is no history accumulation in the SuperGuard.

- ▶ A dotted lined square indicates N/A (not available).

Hotkeys

To reach the Hotkeys screens, press the Hotkey number while viewing the main screen. The room number is located on the upper right side of the Hot screen to view the status of different rooms, first enter the desired room using the room key and pressing the room number. Then press the desired screen Hotkey number.

1 - Main screen

2 - Temperature screen

The temperature Hot screen shows important information regarding the temperature status. You can see the average temperature on the upper left side that shows the average of temperature sensors T1 through T4. On the right side, you can see the temperature for entering tunnel ventilation mode.

T1	24.4		#01
T2	25.1	AVG.	22.9
T3	22.5	TUN.	23.3
T4	23.3	OUT	31.3

Room Number

3 – Targets Screen

This screen shows all of the target levels, selected for any of the controller's functions.

TARGETS		#01
TEMP	22.5	
HHUNIDITY	85	

4 - Curtain Position screen

This screen shows the curtain opening position in percent. If for example curtain 2 show 40%, it is 40% open.

CURTAIN POSITION		#01
CURT.1	50	CURT.2 —
CURT.3	40	CURT.4 —
TUNNEL	—	INLET —

5 - Curtain Target

CURTAIN TARGET		#01	
CURT.1	50	CURT.2	—
CURT.3	40	CURT.4	—
TUNNEL	—	INLET	—

This screen shows the target opening percent for each curtain.

6 - Curtain Steps

This screen shows the number of steps for each curtain.

CURTAIN STEPS		#01	
CURT.1	12	CURT.2	—
CURT.3	14	CURT.3	—
TUNNEL	—	INLET	—

7 - System Status

This screen shows if humidity treatment is ON/OFF, if the cycle is ON/OFF and how many seconds left for the current cycle.

SYSTEM STATUS		#01	
HUMIDITY TREAT.		ON/OFF	
CYCLE STATUS		ON/OFF	
CYCLE LEFT		29	

8 - Variable Status

This screen shows the speed and Heat in percent for the variable devices connected to the controller.

VARIABLE STATUS		#01	
HEAT 1	n/a	heat 2	n/a
FAN 1	30%	FAN 2	40%
FAN 3	n/a	FAN 4	n/a

9 - Relay Status shows active relays, pressing 9 again will open the extension box's relay activity

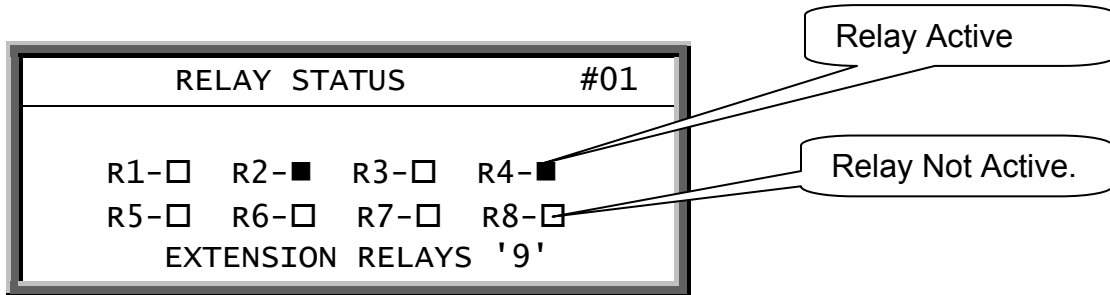

. - (Decimal point) - Weather Station screen

This screen is available if you use ROTEM weather station. This screen displays outside conditions, like Temperature, Rain, Wind Speed, Humidity, Rain Flow and Wind Direction measured by the weather station.

WEATHER STATION		#01	
TEMP	12.5	HUM.	59
RAIN	NO	R.FLW	4
W.SPD	3	W.DIR	172

SuperGuard Setup.

- For SuperGuard setup select room, then 0 and "Enter" from any of the main screens.

The SuperGuard setup is a procedure for customizing the SuperGuard unit to match the system.

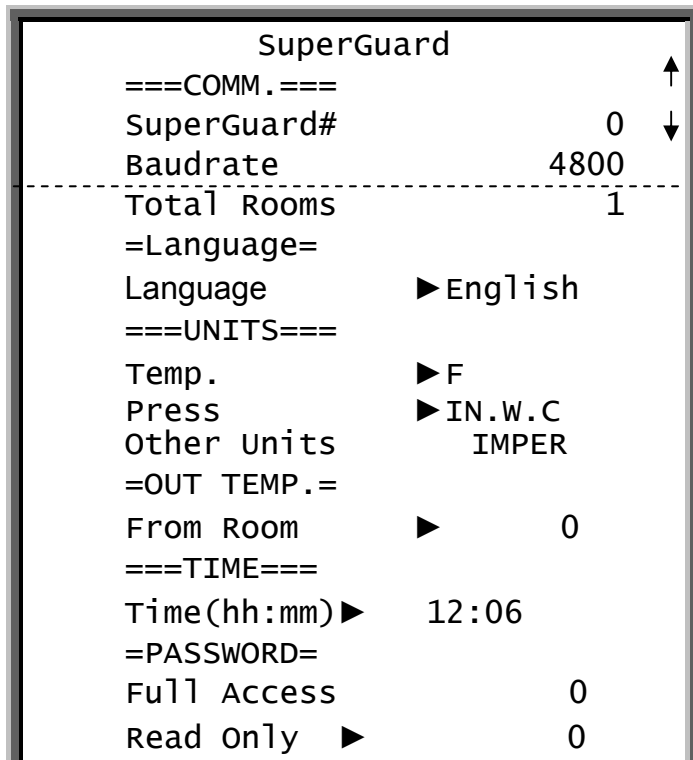

SUPERGUARD	SuperGuard identity (Max-32).
BAUDRATE	Select communication baudrate.
TOTAL ROOMS	Set the number of Piguard Pluses connected to the Super Guard (Max-10). Make sure you define the Piguards' numbers in a following order without skipping digits. For example: 1,2,3,4... If not set this way, the SuperGuard will not detect any Piguard Pluses. After defining the number of Piguard Plus controllers, the SuperGuard begins a search to find the controllers defined.

LANGUAGE	Select language.
TEMPERATURE UNIT	Select between Celsius and Fahrenheit.
PRESSURE	Select between Milibar, IN.W.C, Pascal, CM.W.C, MM.W.C.
OTHER UNIT	Select between meter and imperial. Controls the speed and rain flow. Units for speed are meter/h or mile/h and for rain millimeter/h or inch/h.
TIME	Set clock time.

***<Note>** The last three parameters are general for all of the Piguard Pluses.

Setting tables



Make sure you start any changes by checking the room number on the upper right side of the window.

1. **Time: (hh:mm)** Set a time period for the function you want. You can set up two different time periods for the same function. When more than one time periods correspond, the shortest time frame automatically activates. The chart below shows the active time period as the highest bracket on the Y axis.

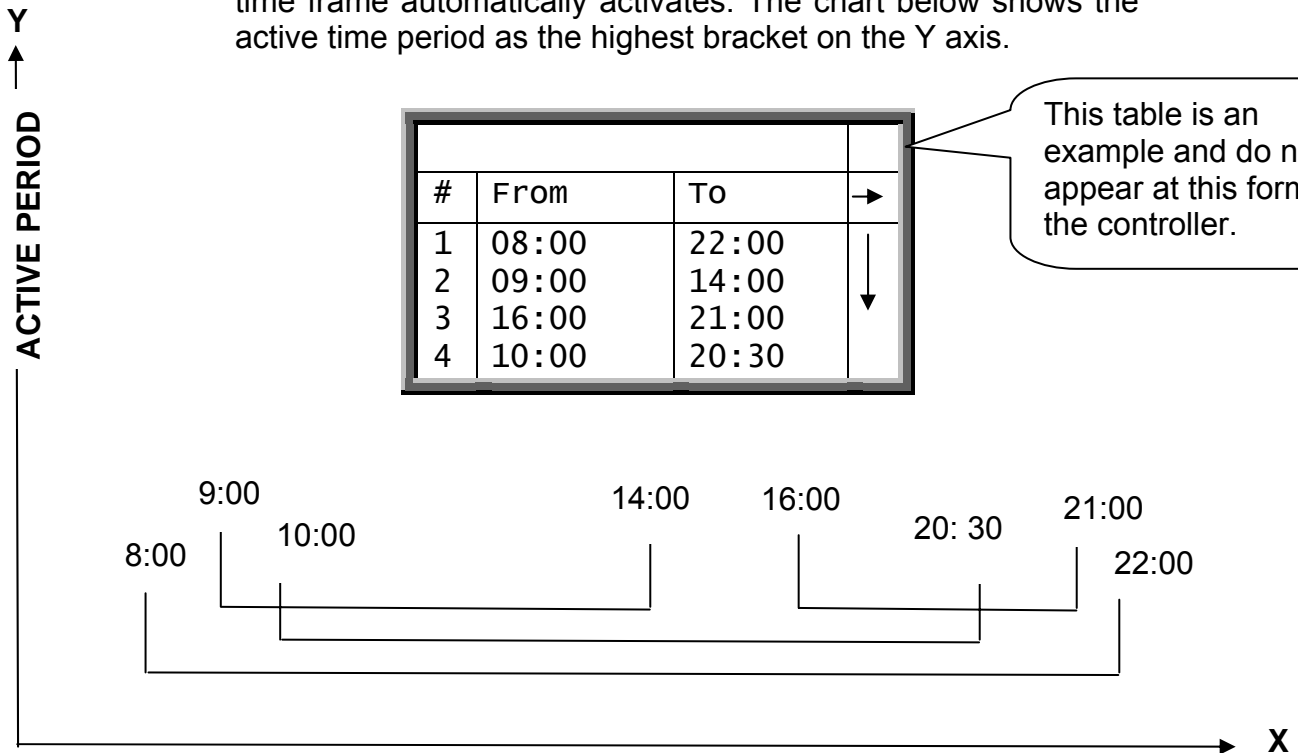

***<Note>** Set on/off time to 0 for no operation and 0 to off time for continues operation.

2. **Floating Point: (format 0.00)** the number of zeroes after the point will determine the resolution.
3. **Function Switcher:** To switch between options use the Round Arrows key.
4. **Scrollbar:** The scrollbar gives an indication on the user's location on the table.

1 CONTROL

1.1 Temp curve

TEMP CURVE #01				Low Alarm	High Alarm
#	Day	Target	→		
1	1	24.0	↓	15	30
2	14	22.0	↓	15	28

The PIGUARD provides separate temperature curves for target and low/high alarms. Set growth day, target temperature and low/high alarm temperatures and the controller will create a curve for each one and use it as reference. The program will alter at midnight prior to the next day on the next row programmed. There are up to 10 programmable rows, but the controller will maintain yesterday's settings for every empty line, therefore it is not necessary to fill the entire table.

Limits:

- Day 0-999
- Target 0-40c
- Alarm low 0-40c (without floating point)
- Alarm high 0-40c (without floating point)

1.2 Humidity

HUMIDITY #01				Inc. Cyc	Inc. Spd
#	Day	Target	→		
1	1	75	↓	30	20
2	14	55	↓	45	30

Set the day and target for a given day. The controller will produce a curve. There are up to 10 programmable rows, but the controller will maintain yesterday's settings for every empty line, therefore it is not necessary to fill the entire table. There are two restrictions under system set-points (menu 67) regarding the humidity treatment: Max vent: high limit ventilation, beyond, treatment is stopped. Max heat: high limit heat, maximum heat allowed by treatment.

Limits

- Day: 0-999
- Target: 0-100%

Inc. Cyc (Increase Cycle Sec.): this parameter is in seconds and will represent the following: in case of a humidity treatment, the controller will increase the cycle on time on the account of the off time by this amount of seconds.

Inc. Spd (Increase Speed Fan %): increase speed fan in the amount of percent set in case of a humidity treatment.

1.3 Min. Vent. Timer

MIN. CYCLE FANS			#01
#Day	On(sec)	Off(sec)	1234
1	60	60	√---
10	90	60	√√--

This function operates without a curve and each day is an independent working day. The program will alter at midnight prior to the next day on the next row programmed.

ON/OFF (sec.): Cycle by seconds.

1234: select the fan to operate during the cycle. In the example above, fan 1 will operate from day 1 to 10 and fans 1+2 will operate from day 10.

1.4 Min Vent Pos.

MIN VENT POS.				V-Fan2	V-Fan3	V-Fan4	INLET	CURTAIN MIN	CURTAIN MAX
#	Day	V-Fan1	→						
1	1	30	→	30	15	20	20	20	70
2	14	35	↓	40	20	25	30	30	80

This table has a different operation for each mode:

1. Minimum Speed Fan and inlet opening percentage, at MINIMUM VENT mode.
2. Minimum and Maximum curtain opening percentage at NATURAL mode.

The settings in both modes are per growth day with a curve between growth days.

Variable speed fans in minimum ventilation:

❖ If the speed is Zero the fans will be OFF in minimum vent and will begin operation according to the parameter in the system parameters.

Note: in case the parameters in this table is different then the one in the system parameter, the system will regard the higher one.

❖ If the speed is less than minimum motor speed in the system parameters then it will work according the minimum motor speed.

1.5 Static Pressure

STATIC PRESSURE #01	
OUT TEMP LOW	5 ↓
PRESS. (LOW T)	0.08
OUT TEMP HIGH	35
PRESS. (HIGH T)	0.12
TUNNEL PRESS.	0.08
LOW ALARM	0.05
HIGH ALARM	0.15
BAND	0.04
WIND DELAY (s)	10
PRE OPEN (s)	5

Out Temp low: Set outside low temperature definition.

Press (Low T): Static pressure target for the outside low temperature (See graph below, point 1).

Out Temp High: set outside high temperature definition.

Press (High T): Static pressure target for outside high temperature (See graph below, point 2).

Tunnel Pressure: Static pressure target during tunnel ventilation mode.

Low Alarm: If static pressure drops below set point alarm will sound.

High Alarm: If static pressure rises above set point alarm will sound.

Band: Set band zone to balance the system.

Wind Delay: Static pressure is affected by wind, this definition is to ensure that an alarm is given due to a stable change in pressure and not an accidental one, that may have been caused by a wind gust.

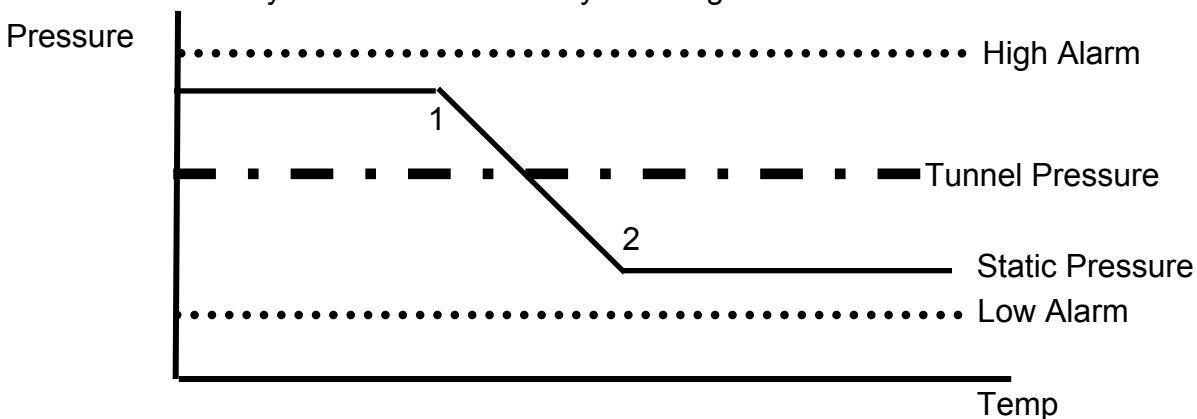

Pre Open: Time setting for curtains to open before fans activate. This is to make sure the curtains are open before fan activity.

1.6 Wind Program

WIND PROGRAM		
	Speed	Opening
Low	10.0	100
High	20.0	30

The values on this screen represent curtain opening percentage for high and low wind speeds. Below the low speed the opening will be 100%, between the low and high there is a curve for the curtain opening and above the high speed, the opening will be according to the high speed.

1.7 System Parameters

TEMP

Offset: Use this parameter to change the offset target temperature up or down for any purpose.

Default: 0

TUNNEL

From Day: From this growth day starts Tunnel Ventilation. 0- tunnel ventilation not active.

Default: 0 (Not active)

Tunnel Curtain Position: the minimum tunnel curtain opening position in % when entering tunnel mode.

Default: 50%

Each Fan open: Additional operating power percentage for fans during tunnel ventilation mode.

Default 10

HUMIDITY

Band: Once the humidity rises above the target, treatment starts operating until dropping below the target + band. That is to prevent from bouncing. Example: The target is 80% and the band is 2%. The treatment will start when reaching 80% and stop only under 78%.

Default: 5

Treat by Heat: Select YES to use heaters at humidity treatment.

Default: Yes.

Treat Delay: Humidity treatment delay time in minutes.

Default: 0 (No treatment)

COOL CELL

From Day: From this growth day cooling starts. 0- Cooling not active.

Default: Day 21

Temp Band: See cooling table page 20.

Default: 0.5°

Humidity Band: See cooling table page 20.

Default: 2%

FOGGER

From Day: From this growth day cooling starts. 0- Cooling not active.

SYSTEM PARAMETERS	
====TEMP=====	
Offset	▶ ↕
====TUNNEL=====	

From Day(0-No)
 Tunnel Curt. Pos
 Each Fan Open
 ===HUMIDITY===
 Band
 Treat by Heat
 Treat Delay (m)
 ==COOL CELL==
 From Day(0-No)
 Temp Band
 Humidity Band
 ===FOGGERS===
 From Day(0-No)
 Temp Band
 Humidity Band
 ===SPEED FAN==
 Min Motor 1 Spd
 Min Motor 2 Spd
 Min Motor 3 Spd
 Min Motor 4 Spd
 Freeze Protect
 ===VAR. HEAT==
 Minimum Heat
 ==WIND SPEED==
 wind Gust (sec)
 Emergency
 Speed for Rain

Default: Day 21

Temp Band: See cooling table page 20.

Default: 0.5°

Humidity Band: See cooling table page 20.

Default: 2%

SPEED FAN

Minimum Speed: Safety speed fan operation delay. This is the Fan minimum speed to begin operation.

Default: 30.

Freeze Protect: A general protection for the variable speed fan motor.

When the variable speed fan starts from zero speed, the freeze protection activates it to 100% for 5 seconds.

Default: No

VAR. HEAT

Minimum Heat: minimum heaters operation for safety measures. This parameter refers to both var. heat 1 and var. heat 2.

Default: 30%

WIND SPEED

Wind Gust: delay time for wind gust or direction change in seconds.

Default: 60 seconds.

Emergency: above this wind speed the system will close all the curtains. The units are meter/h or mile/h according to the selection in the setup screen (room #0)

Default: 20.0

Speed for Rain: in rain time this will be the minimum wind speed for making any curtain position changes in order to prevent rain from entering the room.

The units are meter/h or mile/h according to the selection in the setup screen (room #0)

Default: 10.0

2 DEVICE

2.1 Temp Setting

TEMP. SETTING		#01	
FUNCTION	ON	OFF	
Tunnel	3.0	2.8	
Spd Fan 1	1.0	3.0*	↓
Curtain 1	1.0	1.0	
Curtain 2	1.0	1.0	
FAN 1	0.5	0.0	
H. Lamp 1/2	0.0	0.5	
SET TEMP	(24.0)		
Var. Heat-1	-1.0	2.0*	
Heater 1	-1.5	-1.0	

This example contains several options. All options are available during relay layout and are set according to the devices on your farm.

SET TEMP (Target): Changing the set temperature will change the offset in system parameters. The ON/OFF values are the offset above/below target to trigger cooling/heating.

* The Off value for Variable speed Fans and Variable Heat sets the band range. The example below matches the Temp Setting table and as you can see, the band range for the Speed Fan is 3° and starts at 1° so the controller will create a band between 1 and 4. Above 4° the Speed Fan will operate constantly. The same applies for Variable Heat.

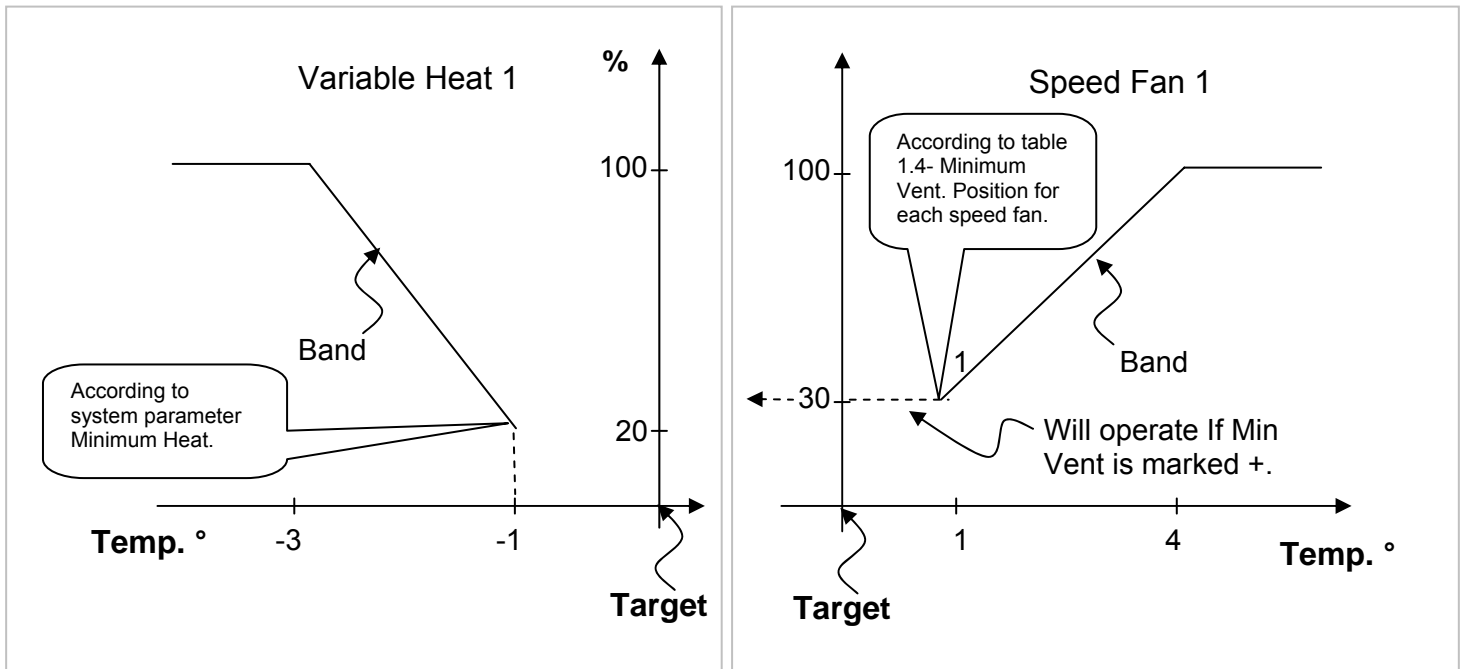

2.2 Curtain

CURTAIN	
====GENERAL====	
Decrease Delay	3.0
Increase Delay	5.0

```

Calibration Steps 99
==CURTAIN NO. 1==
No. Of Stages      5
Operation Mode     AUTO
First Stage (%)    0
==CURTAIN NO. 2==
No. Of Stages      5
Operation Mode     AUTO
First Stage (%)    0
====TUNNEL====
No. Of Stages      5
Operation Mode     AUTO
First Stage (%)    0
    
```



Dip Switch Configuration:

On the PiGuard Plus's CPU there are two parallel blue dip switches, located on the left hand side of the PCB. If you want hardware protection during curtains' activity, make sure you connect the curtains in pairs, according relay numbers (1,2; 3,4; 5,6; etc.) and to move the three matching dipswitches to off position. On the PCB is written which switch goes with the relay. Not doing so may result in the motors closing and opening the curtains simultaneously, due to bad configuration or programming on behalf of the user.

GENERAL

Increase/Decrease Delay: delay at least the length of time specified in this section before moving again.

Calibration Steps: After moving the number of times specified in stages for calibration, the curtains go to the nearest limit (fully open or fully closed) one at a time in order to calibrate their position counters. Whenever any curtain reaches one of the limits, its calibration counter automatically resets.

CURTAIN NO. ½

No. Of stages: Divide the curtain stages for opening and closing and the controller will translate the number into percentage. (In the table above each stage is of 20%)

Operating Mode: In Auto mode the controller will manage the opening/closing or you can manually open/close or stop the curtain all together.

First Stage: This option allows programming an individual percentage for the first stage

2.3 Cool Cell

The cooling table provides settings for the evaporative cool cell system. There

Cool Cell		#01		Diff	%RH	On	Off
#	From	To	→				
1	08:00	20:00	↓	3.0	85	30	90
2	10:00	18:00	↓	5.0	75	60	60

are up to 10 fragments allowing precise control over this system. Several fragments can be selected for the same day.

FROM: (HH:MM) Start time.

TO: (HH:MM) End time.

DIFF: Differentiation from target temperature to activate cooling. When temperature raises diff above target, cooling process will begin. When temperature reduces back to target, cooling process will stop.

%RH: As long as the humidity + Band are below this level the cooling operates. Cooling stops only at humidity level + band. (See figure below)

ON/OFF: (sec) On/Off cycle by seconds.

BAND: The cooling table has its own 'happy zone' for temperature and humidity that can be set at the system parameters under cooling section. The cooling system turns on the amount above specified in the column 'Diff' and turns off when the temperature drops the amount specified in the band.

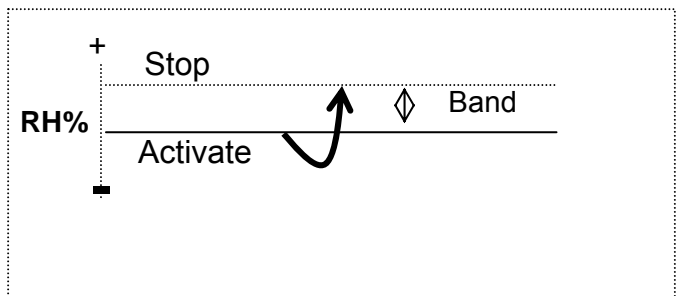
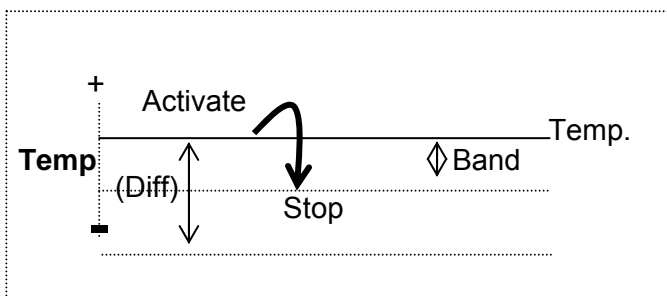

2.4 Foggers

The Foggers' table provides settings for the fogger system. There are up to 10

COOLING #01							
#	From	To	→	Diff	%RH	On	Off
1	08:00	20:00	↓	3.0	85	30	90
2	10:00	18:00	↓	5.0	75	60	60

fragments allowing precise control over this system. Several fragments can be selected for the same day.

FROM: (HH:MM) Start time.

TO: (HH:MM) End time.

DIFF: Differentiation from target temperature to activate cooling. When temperature raises diff above target, cooling process will begin. When temperature reduces back to target, cooling process will stop.

%RH: As long as the humidity + Band are below this level the cooling operates. Cooling stops only at humidity level + band. (See figure below)

ON/OFF: (sec) On/Off cycle by seconds.

2.5 Light

LIGHT			
#	Day	From	To
1	1	14:00	12:00
2	5	10:00	16:00

Set the on/off times according to growth day, there are up to five programmable lines.

2.6 Feed

LIGHT			
#	Day	From	To
1	5	10:00	12:00
2	10	14:00	16:00

Set from what hour to what hour you want the feeding to take place, there are up to five programmable lines.

2.7 Extra system

EXTRA SYSTEM #01				F.Temp.	T.Temp.	on	off
#	From	To	→				
1	10:00	12:00	↓	60	240	20	50
2	14:00	16:00		60	60	30	60

Any relay can be set as an extra system.

The extra system's relays will activate according to the settings in this table and regardless of the conditions, or other devices.

FROM: (HH:MM) Start time.

TO: (HH:MM) End time.

To/From Temperature(F.Temp/T.Temp): the temp range for extra system activity.

ON/OFF: (sec) On/off cycle by seconds.

This table has up to ten programs.

3 MANAGEMENT

3.1 Animal inventory

ANIMAL INVENTORY #01	
Add Mortality	2
Animal Placed	1000
Animal Update	998

This table provides an update for animal inventory.

Add Mortality: insert mortality.

Animals Placed: insert animals placed.

Animal Update: update number of animals.

- In case the wrong figures are accidentally entered, it is possible to correct them by entering negative figures.

3.2 Day & Group

DAY & GROUP #01	
Growth Day	2
New Group	Yes/no
Group No.	4

Day and group keeps monitor the growth of groups

Growth Day: Set the number of growth day. This parameter can also help determine the animals age.

New Group: To start a new group, select YES under new group fragment and the controller will automatically increase group number by one and set growth day to 1.

Warning: When starting a new group, history will be deleted!!!

Group No.: You can manually change the group number.

3.3 Alarm setting

ALARM SETTING	
Alarm Delay	▶ 60 ↑
=SENSOR RANGE=	
High Range	10 ↓
Low Range	50
====HIGHE TEMP=====	
Out Compensate	0.0
Emergency Temp	35
====LOW TEMP=====	
Var Fan Stop	NO
===WATER & FEED===	
Max water/hour	0
Max Feed/hour	0
===Aux. Alarm===	
Aux Relate f()	NONE

ALARM SETTING

Alarm Delay (sec): represents the number of seconds between failure detection and the alarm operation.

***<Note>** If the problem is solved before the delay time ends, an alarm will not be recorded in the history log.

SENSOR RANGE

Low/High: High and low temperature ranges beyond which alarm is activated.

HIGH TEMP

Out Compensation: This parameter is added to the high temperature alarm when outside temperatures are high, like noontime in desert countries. Ensuring you won't get an alarm just because it's a hot day. The emergency temperature has no compensation, so the compensation feature only works when temperatures do not exceed the emergency temperature.

Example: Outdoor+comp. >Alarm then Alarm=Outdoor+Comp.

For example: IF the pre set compensation is 2°F, the outside temperature is 75°F and alarm is set to 76°F, the controller adds the outside temperature to the comp, and the alarm will rise to 77. (75+2=77)

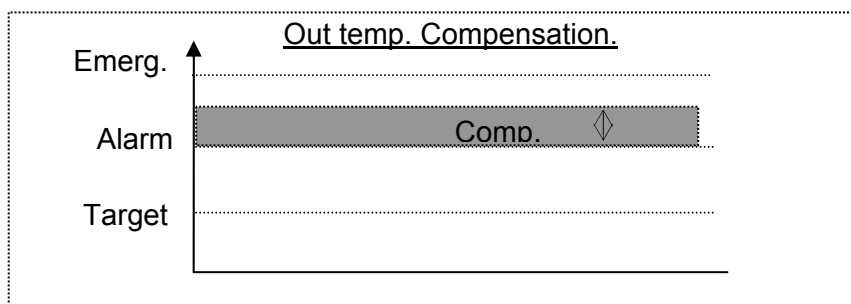

Emergency Temp.: The temperature beyond which the controller goes into emergency mode and an alarm is activated.

LOW TEMP

Variable Speed Stop (Yes/No): When in low temperature alarm, decide whether to keep variable speed in minimum operation or totally shut down the function.

WATER & FEED

Max Water/Hour: A quantity of water per our, above which alarm will activate.

Max Feed/Hour: A quantity of feed per our, above which alarm will activate.

AUX. ALARM:

- When assigning a related function, alarm occurs if the associated digital input fails to follow the relay. Digital input must be active when its associated relay is on.
- If there is no related function the alarm will turn on when digital input is active.

3.4 Alarm Reset

ALARM RESET	#01
Alarm Reset	▶NO

***<Note>**

To reset the alarm press Enter and use the Round Arrows key to change from NO to YES.

3.5 Password

- * Full access -Password grants complete control.
- * Read access - Password grants read access only.

4 HISTORY

***<Note>** The history section maintains a memory of activity of the last 100 days and 100 events or alarms.

4.1 Temperature

TEMPERATURE			#01
DAY	MIN	AVG	MAX
1	24.5	26.6	27.0
2	24.0	25.0	26.0
...			
99			

4.2 Humidity

HUMIDITY			#01
DAY	MIN	AVG.	MAX
1	70.0	80.0	90.0
2	75.0	85.0	95.0
...			
99			

Sensors: Data collection for minimum, maximum and average in temperature and humidity for the last 100 days.

4.3 Water

WATER #01		
DAY	DAILY	%
1	30.0	N/A
2	27.0	5
.99		

DAY: Growth day.

DAILY: Daily consumption.

%CHANGE: % Change from previous day.

4.4 Feed

FEED #01		
DAY	DAILY	%
1	15.0	N/A
2	10.0	-33
3	20.0	100
.99		

DAY: Growth day.

DAILY: Daily consumption.

%CHANGE: % Change from previous day.

4.5 Mortality

MORTALITY #01		
DAY	DAILY	TOTAL
1	0	N/A
2	1	1
.100		

DAY: Growth day.

DAILY: Daily mortality.

TOTAL: Mortality total since growth day one.

4.6 Heater

HEATER ROOM #01		
DAY	Heat 1	Heat 2
1	1:05	00:15
2	00:42	00:02
.99		

The history heater will show the amount of HH:MM the heater was on that day.

4.7 Alarm

ALARM #01			
	MESSAGE	TIME	DAY
■	Press. Fail	18:50	18
▣	High Temp	10:45	14



The following is an example of an Icon status that indicates activation of alarms.

- NOT ACTIVE
- AN ALARM THAT WAS RESET
- ACTIVE

There are 21 different possible alarm messages:

1. Ana. In Fail - analog input failure
2. High Temp - high temperature alarm
3. Low Temp – low temperature alarm
4. Hum.Sen Fail- humidity sensor failure
5. Lost Comm- lost communication
6. W. Overflow- water over flow
7. F. Overflow- feed over flow
8. Sn. 1 Fail – Sensor #1 failure.
9. Sn. 2 Fail
10. Sn. 3 Fail
11. Sn.1 Def Err- sensor definition error
12. Sn.2Def Err
13. Sn.3 Def Err
14. Sn.1 Out Rng- sensor out of range
15. Sn.2 Out Rng
16. Sn.3 Out Rng
17. Sn. Not Def- sensor not defined
18. Aux Alarm- auxiliary alarm.
19. Press. Fail
20. Low S. Press.
21. High S. Press.

4.8 Event

EVENTS ROOM #1			
	EVENT	DAY	TIME
1	Menu #11	2	18:53
2	Power up	4	14:42

Besides the menu # event message there are three kinds of events:

1. Power up- how many times the controller was turned on.
2. Reset- how many times the controller was reset.
3. Cold- how many cold starts were performed.

The events table is similar to the alarms table but without icons. For example: In the table above “menu #11” means that there was a change of settings in this menu.

5 SERVICE

5.1 Temp calibration

TEMP. CALIB.	#01
Temp-1(Factor)▶	0.0
Temp-2(Factor)	0.0
Temp-3(Factor)	0.0
Temp-4(Factor)	n/a

- **The temperature sensor is a very accurate sensor with a deviation of 0.1.**

If needed, calibrate the temperature sensor by using a very accurate reference instrument and enter the offset number for each sensor in the Temp factor line. Use the up and down arrow keys to select sensors.

5.2 Humidity calibration

HUM. CALIB.	#01
Humid.(factor)▶	0.0

If needed, calibrate the humidity sensor by using a very accurate reference instrument and enter the offset number in the Humidity factor line.

5.3 Pressure calibration

PRESS. CALIB.	#01
value	A/D
Press ENTER to calib	

5.4 Analog Output

Select the minimum Volt percentage for each output.
(The default is 30%)

ANALOG OUTPUT #01		
#	0%	100%
Output1 ▶	0.0V	0.0V
Output2	0.0V	0.0V
Output3	0.0V	0.0V
Output4	0.0V	0.0V

The minimum Voltage is used to protect your electric equipment.

If the min. is 30% and 10% operation was set for the Output; the controller will run on 37%.

5.5 Water & Feed

water/feed #01	
water per pulse	0.1
Feed per pulse	1.0

The water and feed system operates on a pulse counting method.

Enter the amount of feed/water per pulse.

5.6 Version

Observe the Piguard software version.

5.7 Read Plug

Read Plug?	
NO◀	YES

Use the arrow keys to shift from NO to YES and press Enter to read from data plug.

5.8 Write Plug

write Plug?	
NO◀	YES

Use the arrow keys to shift from NO to YES and press Enter to write over the data plug.

6 INSTALLATION

6.1 Relay layout

#	FUNCTION	MNT
	None	---
	None	--- ↓

Each relay can be defined to any of the functions on the following list:

- None
- Heater 1-2
- Heat lamp 1-2
- Fan 1-8
- Cool Cell
- Curt. 1 open
- Curt. 1 close
- Curt.2 open
- Curt 2 close
- Tunnel open
- Tunnel close
- Inlet open
- Var. inlet Open
- Var. inlet Close
- Inlet close
- Extra system
- Alarm

MNT: Minimum Vent / Natural / Tunnel

Use the Round Arrows key to run through the list of functions and press enter to select a function.

***<Note>** As long as the function is marked with a minus sign, it will not operate even if the conditions are suitable.

6.2 Sensors

ANALOG INPUT #01		OPTIONS
Temp-1	IN	IN / NONE
Temp-2	NONE	IN / NONE
Temp-3	OUT	IN / NONE
Temp-4	YES	NO / YES/OUT
Humidity	YES	NO / YES

The Analog inputs accommodate up to three temperature sensors and one humidity sensor. Two can be defined for use inside the house and up to one can be used out of the house. Just mark "in" for a temperature sensor connected in the house and out for a temps. Sensor outside of the house.

6.3 Digital input

DIGITAL INPUT #01		OPTIONS
Input-1	Water	None / Water / Feed / Aux. Alarm
Input-2	Feed	
Input-3	None	

There are 3 digital inputs and a selection between water, feed, aux. alarm or none.

AUX. ALARM: Once operating function, a digital input is sent to make sure that it is actually on, and if not the alarm starts.

6.4 Analog output

ANALOG OUTPUT #01		
#	FUNCTION	MNT
1	Var. Heat 1	---
2	Var. Heat 2	---
3	Var. Fan 3	---
4	Var. Fan 4	---

Use the Round Arrows key to run through the list of outputs and press enter to select an output.

MNT: Minimum Vent / Natural / Tunnel

6.5 Variable Speed Fan

VAR. SPEED FAN #01		
	ACTIVE	MNT
1 VAR. Fan 1	▶ YES	---
2 Var. Fan 2	YES	---

6.6 Sensor Definition

FUNCTION	1234
Average	+--+
Tunnel	+---
Heater 1	+---
Heater 2	-+++
Heat Lamp 1	-+--
Heat Lamp 2	---+
Fan 1-8	---+
Curtain 1-2	++--
Cool cell	----
Ex. System	----
Tun. Curt	---+
Speed fan	----
Var. Heat	--+-

Select the temperature sensors 1-4 to use for each function using the Round Arrows key to apply and remove check marks.

*<Note>

Average- the average definition refers to the average temperature, according to the sensor defined. If two minus symbols are defined for a certain sensor, that sensor will operate according to the average temperature definition.

6.7 Curtain Setup

CURTAIN SETUP #01		
CURTAIN	OPEN	CLS
Curtain1▶	60	60
Curtain2	60	60
Curtain3	60	60
Curtain4	60	60
Tunnel	60	60
Inlet	60	60

Curtain Setup tells the controller how fast your curtains and side inlets move. It needs this information to properly calculate automatic inlet advance as well as inlet and curtain positions.

Piguard Pluses

Cold Start

In order to execute a cold start, disconnect the power, then reconnect the power while pressing the 3 buttons of the Piguard Plus together and hold them for about 2 seconds.

The following will appear:



When this screen appears the controller performed a cold start.

- Cold start will erase all data and history from the memory and load factory defaults!!!

Set Unit Number

Press the two arrow key simultaneously until NO. is blinking.

Set the unit number with the up and down arrows and press Select.

Main Menu

Once the **Piguard Plus** is activated the main screen will appear showing the inside average temperature of the rooms. Pressing SELECT allows the user through the main screen's information.

trg: The target temperature for the room. (Can be changed from the Piguard Plus itself only if a curve was not defined.)

rH: Humidity in room.

rH.t: Target humidity.

day: Growth day for the room.

The display alternates between the name and the figure.

Calibration

Temperature sensors are very accurate and most likely will not require calibration.

However, if calibration is required it will be done in the following way:

Temperature sensor calibration

- Use an accurate thermometer reference.
- Place it near the temperature sensor.
- Make sure that the inside temperature is stable.
- Calibrate the temperature sensor immediately after reading.

Calibration procedure

1. In order to get to the calibration menu press "select" and the "up" arrow keys simultaneously and hold them together for about two seconds.
2. The display alternates between the sensor number and the temperature measured.
3. Use the arrow key to change the temperature.
4. Press select to move through the sensors and the arrows to change temperatures

NOTE: Calibration of humidity sensor is done exactly the same way; the only difference is that instead of measuring temperature, the humidity is measured by an external humidity sensor.

Test

The test option is used mostly in the installation process and it enables the installer to check systems.

In order to get to test menu, press “select” and “down” arrow keys simultaneously and hold them together for about two seconds.

The display alternates between the name of the I/O and an ON/OFF sign.

Pressing the arrow keys allows switching between on and off.

rL.1-7: Relays 1 to 7.

SPd: Variable speed. (Check minimum to full capacity using the arrow keys)

AO1-4: Analog outputs 1 to 4.

t1, t2: Temperature sensors with the A/D counts blinking on the screen.

Hu: humidity sensor A/D counts.

Ai1-2: Analog inputs 1 to 2.

Prs: Pressure A/D counts.

DG1-3: Digital inputs 1 to 3.

Technical Specifications

Power supply

Mains voltage	single phase	115/230VAC
Main fuse		315 mA
Secondary fuse		1 A
Maximum power consumption		10VA

Available power for peripheral equipment

Analog Inputs

2 analog inputs for temperature sensors	RTS-2 (THERMISTOR)
5 analog outputs	20MA 0-:-10V
1 humidity sensor inputs	0-:-3V
2 analog inputs	0-:-5V

Digital inputs

3 digital inputs	dry contact	5V/2mAmp
------------------	-------------	----------

Relays outputs

7 N.O. power relay	2HP	30Amps	250vac
--------------------	-----	--------	--------

Housing

Dimensions (LxWxH)	92.5x73x36
--------------------	------------

Ambient climate

Operating temperature range	32° F to + 122°
Storage temperature range	14° to + 158°

Indoor Applications

The equipment is designed for use in Indoor Applications only!

Environmental Protection



Recycle raw materials instead of disposing as waste. The controller, accessories and packaging should be sorted for environmental-friendly recycling. The plastic components are labeled for categorized recycling.

Piguard Plus Installation Guide.

Sensors and Shielded Wiring



1. For long shielded wires, connect the shield to ground at **one end** only.
2. From the ground terminal, run a heavy wire directly to the ground rod. It is acceptable, if necessary, to run the heavy ground wire to the electrical service grounding system rather than directly to the ground rod.
3. Do not use light wires for these ground connections. They must carry heavy lightning currents, sometimes exceeding thousands of amperes. Certainly, do not use the shielding of sensor and low voltage wiring for this purpose.
4. Ensure that all ground connections go to a single local point. When lightning strikes, grounds a meter or two apart will be at significantly different voltages. If you have several electronic boxes with individual grounds, connect all these together to a single point (If Possible), preferably to the surge protector ground. This should continue to the ground rod or the electrical service. In particular, avoid grounding any controls remotely through shield wiring.
5. Do not use shields to create a path for lightning. For long shield wires, such as building to building runs, connect the shield to ground at **one end** only, to reduce the chance of conducting lightning from one building to another.
6. When splicing sensors to longer wires, ensure that the splice is **waterproof**. Use adhesive lined heat shrink (marine grade) to make waterproof connections.
7. Use a good compression connector for splicing. This is better than soldering. Do not simply twist wires together and then cover with electrical tape.
8. Keep sensor wiring separate from other power distribution and high voltage wiring. Ensure that lightning on other wiring will not transfer to the sensors.
9. Install outside temperature sensors so that the sun will not cause false readings, and so that exhaust air from the building will not affect the sensor.

Installation and Electrical Connections

1. Install computerized electronic controls at least one meter (three feet) away from interference sources such as high voltage wiring to motors, variable speed, light dimmers, relays.
2. Install electronic controls in a separate ventilated control room that is protected from extreme temperatures and dirty environments. Place the controls so that the operators can conveniently use the control and read indicators and displays.
3. Give your installation a professional appearance, with all wiring in conduit or neatly installed. Keep low voltage wires separate from high voltage wires.
4. Use shielded wiring for low level signals. For buried wiring (building to building runs) use high grade jell filled cables that are impervious to moisture.
5. **Seal** cable entry points and control boxes to prevent contamination and corrosion. If you use silicon sealant with acetic acid cure, keep the control open and ventilated until cured. Otherwise, the acetic acid will attack the metal parts, including circuitry.
6. Drill cable entry holes on the bottom of the box only.

Mechanical Installation Guide



The **Piguard PLUS** must be installed by an authorized electrician. Power must be disconnected to avoid electrical shock and damage.

To avoid exposing the **Piguard Plus** to harmful gases or high humidity, it is recommended to install it in the service room.

Installation Category (Over voltage Category) II

The power supply to the controller should be protected by 10 Amps circuit breaker

All electrical connections should comply with National Electrical code (NEC)

1. Screw the metal sheet on the back of the box using the 4 supplied screws. Mount the Piguard Plus through the mounting holes. (see next page)
2. Open the enclosure lid by unfastening the four screws.
3. Drill holes at bottom of the box and place cable holders.
4. Place the required cables through the cable holders at the bottom of the unit. Connect the wires according to the wiring diagrams.
5. Make sure that you use wires large enough for the load of the variable speed.
6. To connect temperature and humidity sensors use shielded two or four conductor #18-#24 gauge cables. Connect the shields to the Ground metal strip. Do not connect the shields to more than one point, or you may induce ground loop currents.
7. Close the Piguard Plus enclosure lid carefully and tightly. Use RTV silicon or equivalent sealant to seal the cable holders.
8. After installation is completed, operate the Piguard Plus for a few hours and re- check for proper operation.

Metal Sheet Assembly Diagram

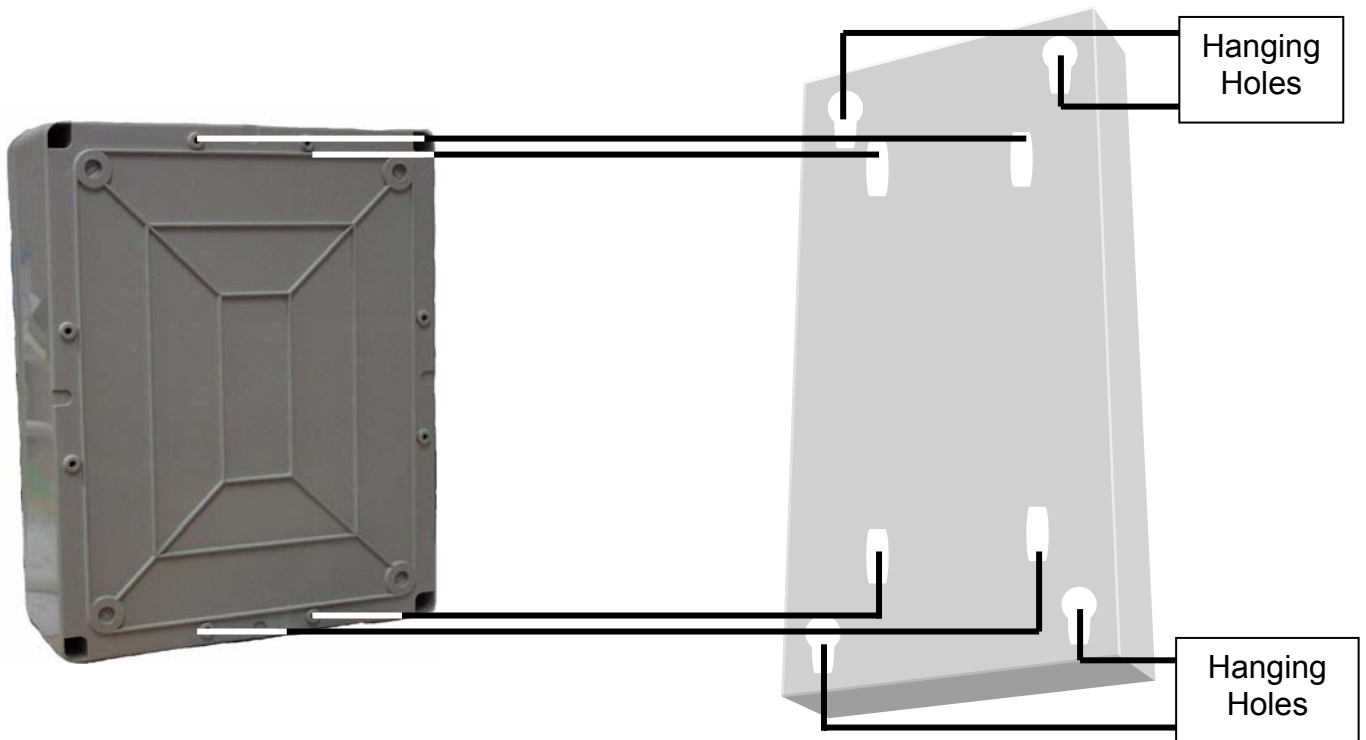

Instructions

1. Screw the metal sheet on the back of the controller (Clear side facing controller) using the supplied four screws.
2. Measure the outer hanging holes of the sheet and drill hanging screws parallel to the holes.
3. Hang the controller.

SuperGuard/Piguard Plus Network Connection

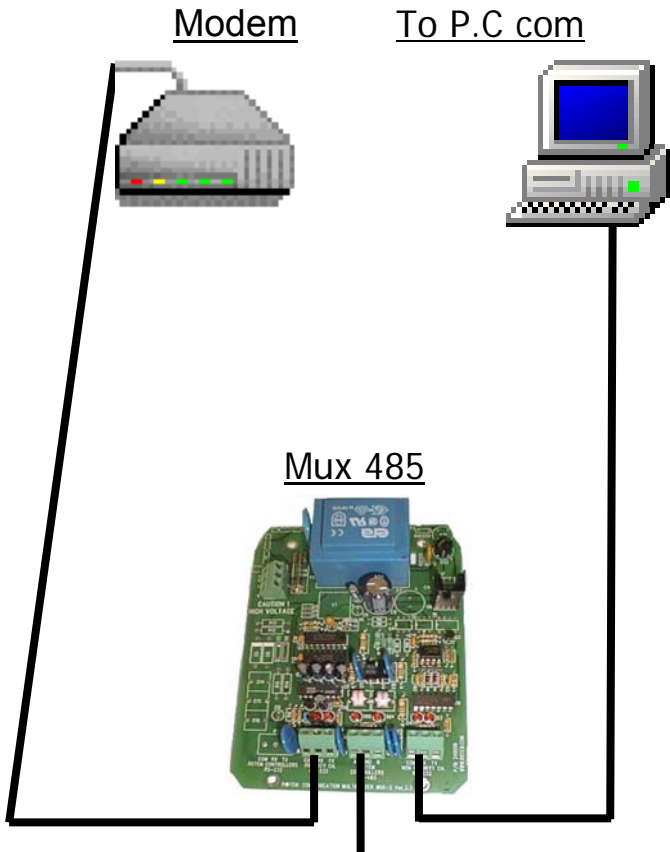

Dip Switch Configuration:

On the PiGuard Plus's CPU there are two parallel blue dip switches, located on the left hand side of the PCB. If you want hardware protection during curtains' activity, make sure you connect the curtains in pairs, according relay numbers (1,2; 3,4; 5,6; etc.) and to move the three matching dipswitches to off position. On the PCB is written which switch goes with the relay. Not doing so may result in the motors closing and opening the curtains simultaneously, due to bad configuration or programming on behalf of the user.

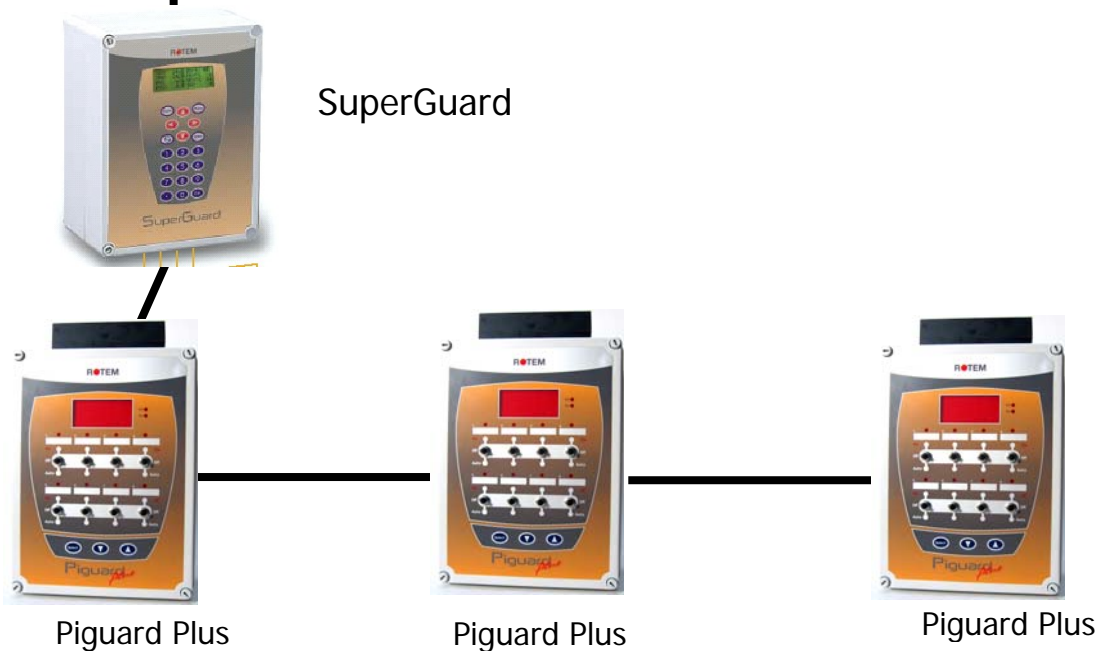

Piguard Plus Wiring Diagram
(Analog Output, Power, Variable speed, RHS-2)

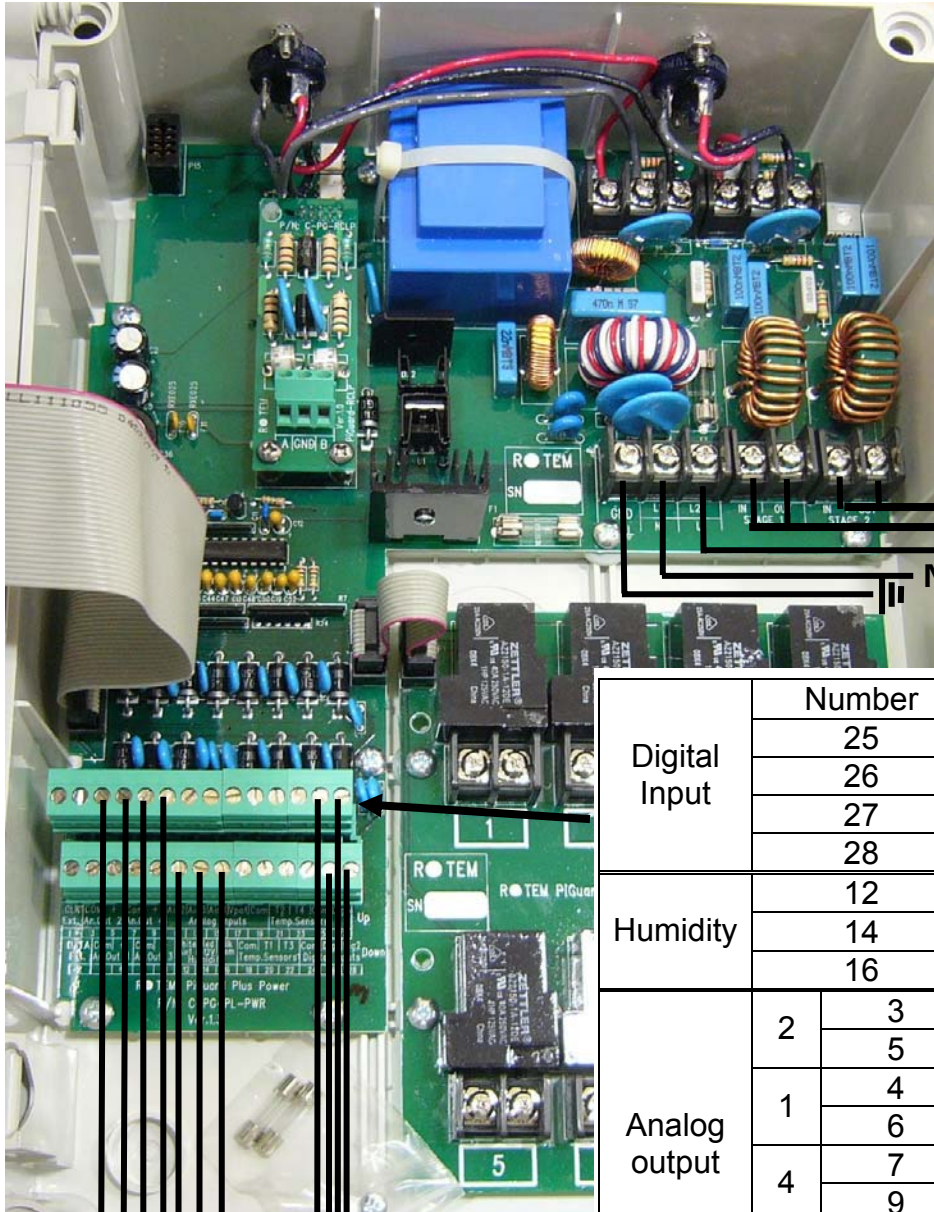

Variable speed 1 & 2

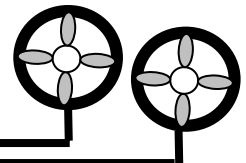

Power

	Number	Wire	
Digital Input	25	COM	
	26	Dig 1	
	27	Dig 3	
	28	Dig 2	
Humidity	12	White	
	14	Red	
	16	Black	
Analog output	2	3	COM
		5	+
	1	4	COM
		6	+
	4	7	COM
		9	+
3	8	COM	
	10	+	

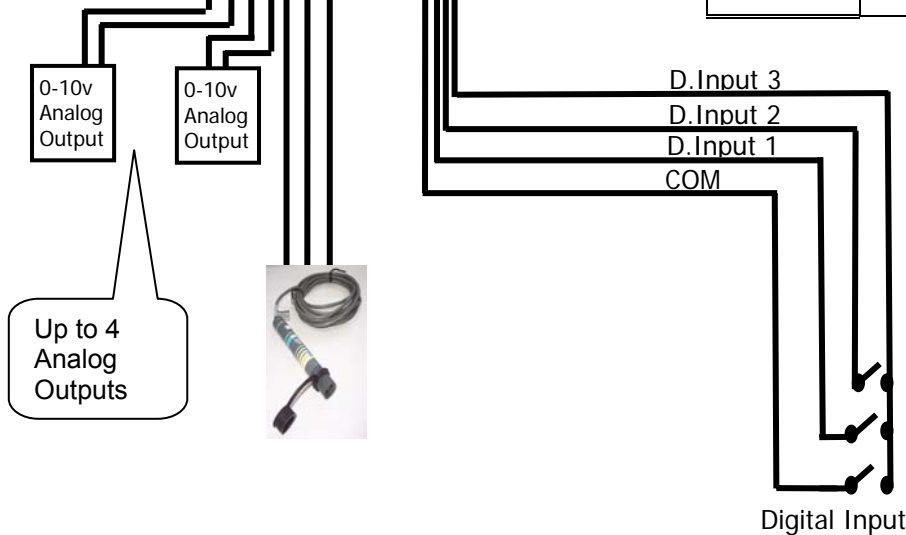

Piguard Plus Wiring Diagram
(Relays, Potentiometer, RTS-2)

	Number	Wire
Temperature sensor	18	COM
	20	T1
	21	T2
	22	T3
	23	T4
Analog input	11	A. in 2
	12	A. in 1
	13	A. in 3
	15	A. in 4
	17	Vpot
	19	COM

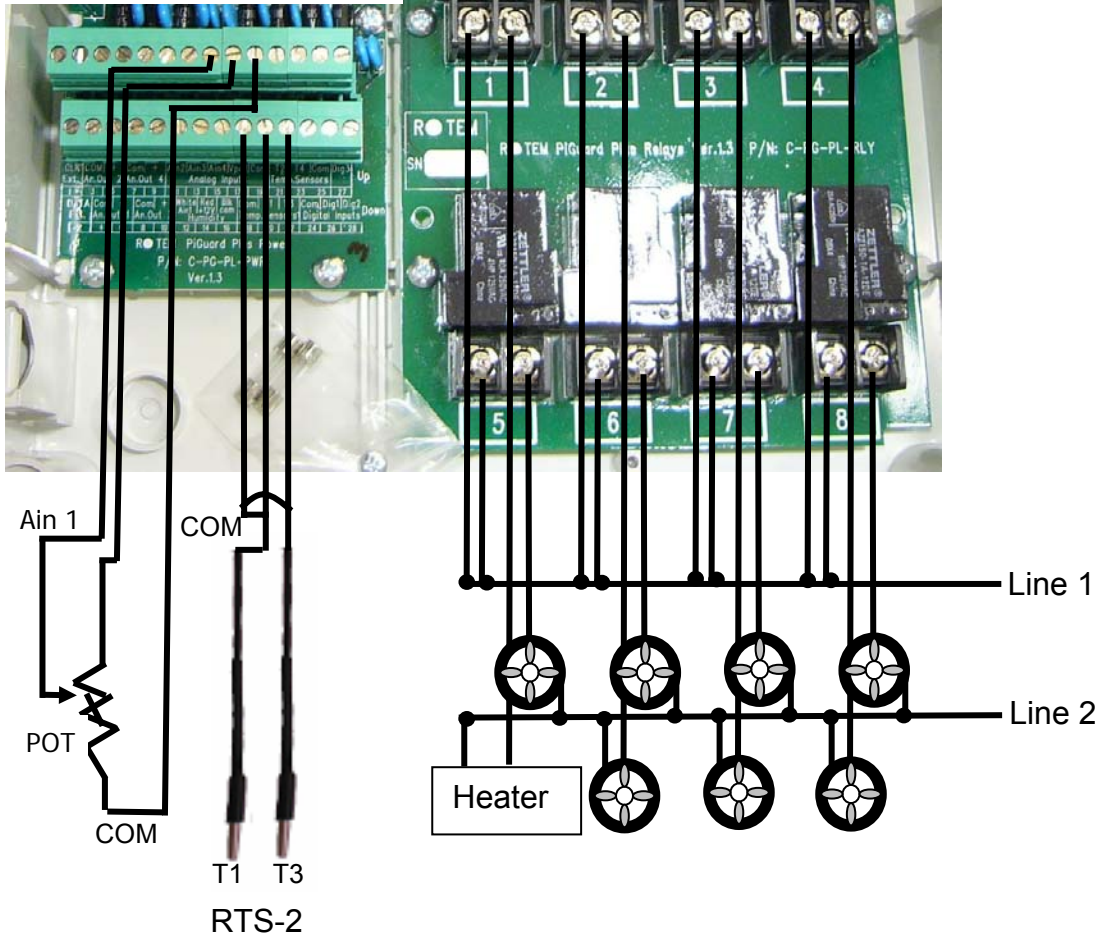
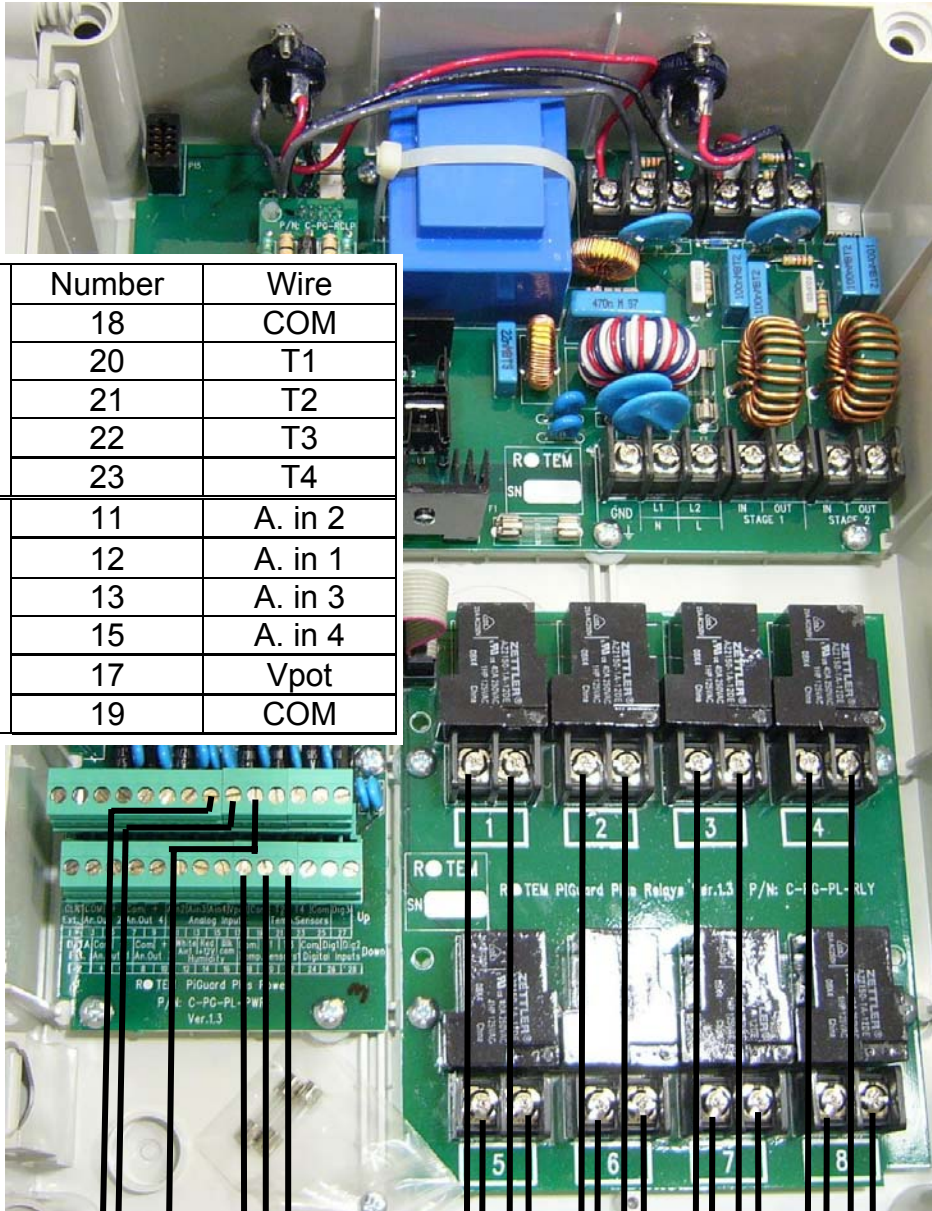

Communication Wiring Diagram

To P.C. com.

Modem



Mux-485



com, rx, tx

SuperGuard



com, rx, tx

A to A, B to B (shield to GRD at one end only)



Room 3

Room 2

Next Room

Previous Room

Room 1



Shield connected



Shield is connected to GND only on one end to each piece of cable



Shield connected

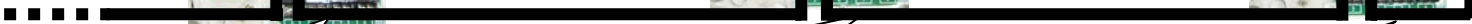

Piguard Plus Wiring Diagram Extension Box

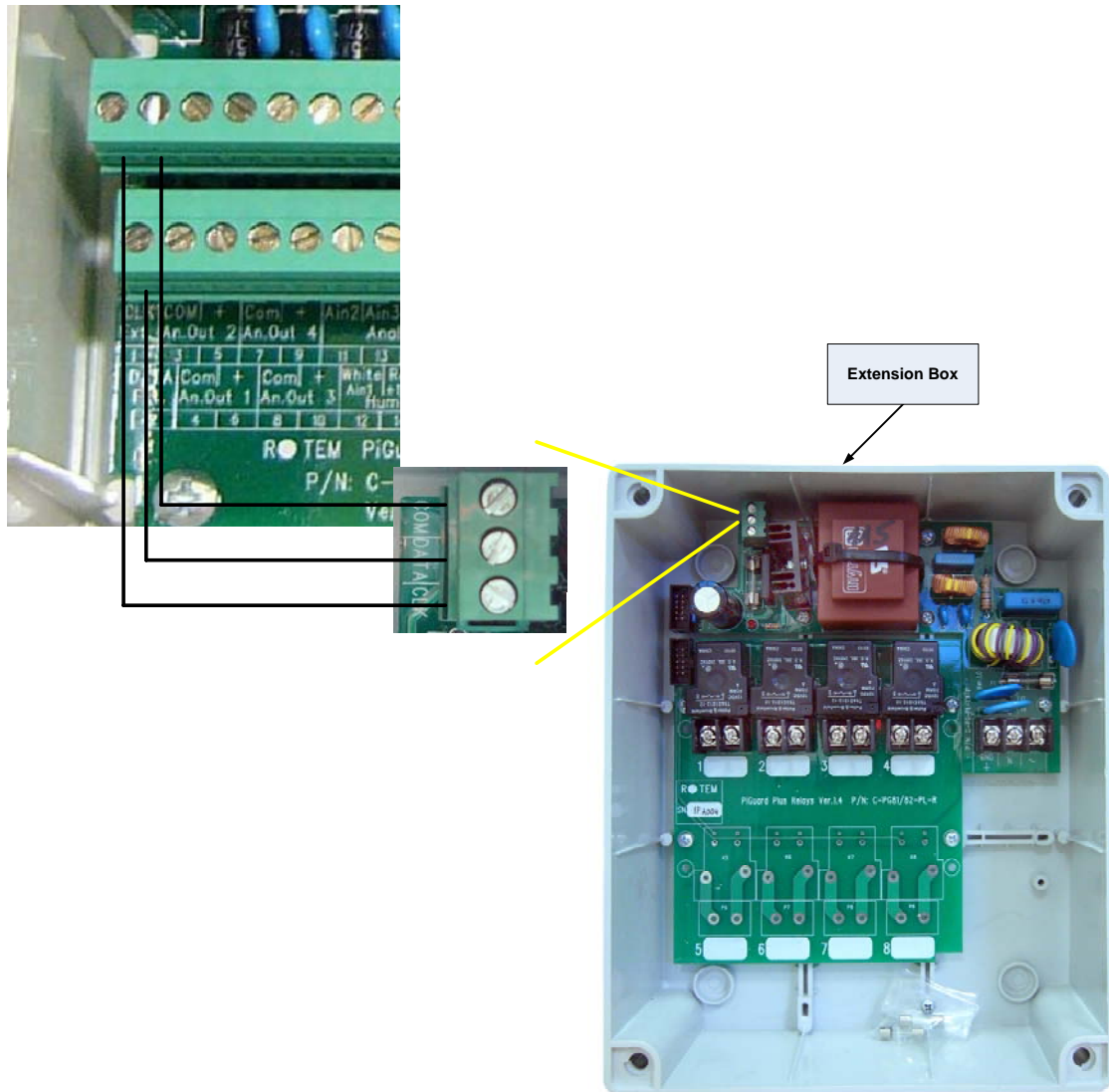

When connecting the relevant connections (see above) the connections of both the Piguard Plus and the Extension box unit must be with no power. Before turning the Piguard Plus on, make sure the Extension box is plugged in first, so that the Piguard Plus identifies the Extension box.