

# BELT DRIVE GALVANIZED SLANT WALL FANS



**RAY•DOT**  
LLC

**VALAIR™**

### Step 1.

Unpackage and become familiar with all of the fan components and hardware. The legend below will help to familiarize you with the hardware required for this assembly.

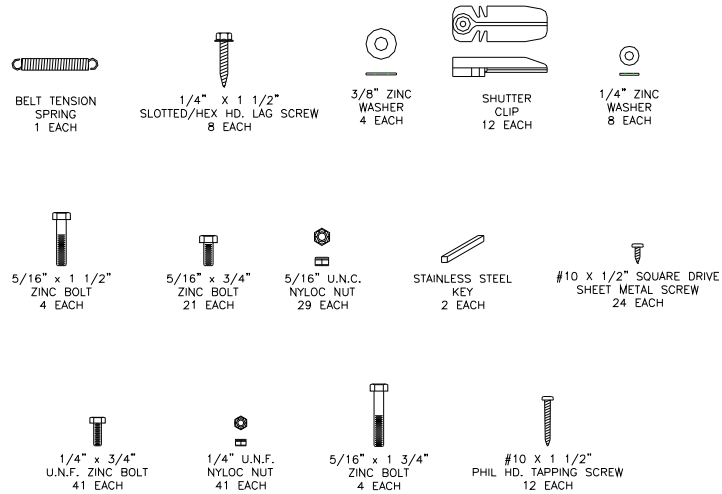

### Step 2.

Insert the shaft into one of the pillow block bearings, making sure the bearing setscrew is toward the middle of the shaft. Keep 2" of the shaft extended from the race of the bearing. Tighten the setscrew to hold this bearing in position. Slide the other bearing onto the other end of the shaft, making sure the setscrew is toward the middle of the shaft. Do not tighten the setscrew at this time.

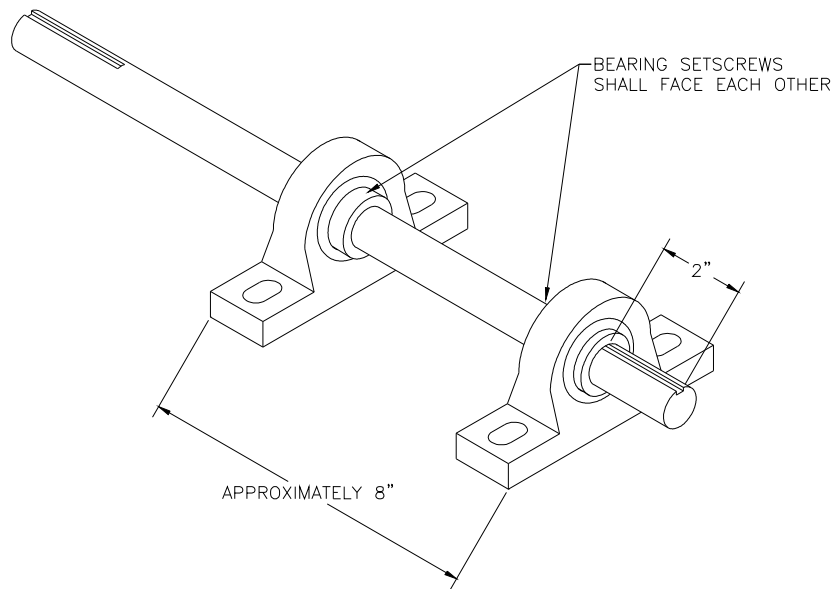

Step 3.

Mount the bearing / shaft subassembly to the J-frame motor / bearing mount. Keeping the bearings centered on the J-frame motor / bearing mount, insert the 5/16" – 18 x 1 1/4" bolts, with 3/8" S.S. washer, into each of the bearing holes. The long end of the shaft must end up on the side of the J-frame motor / bearing mount attached to the two mounting bars. Complete fastening with the 5/16" – 18 nyloc nuts.

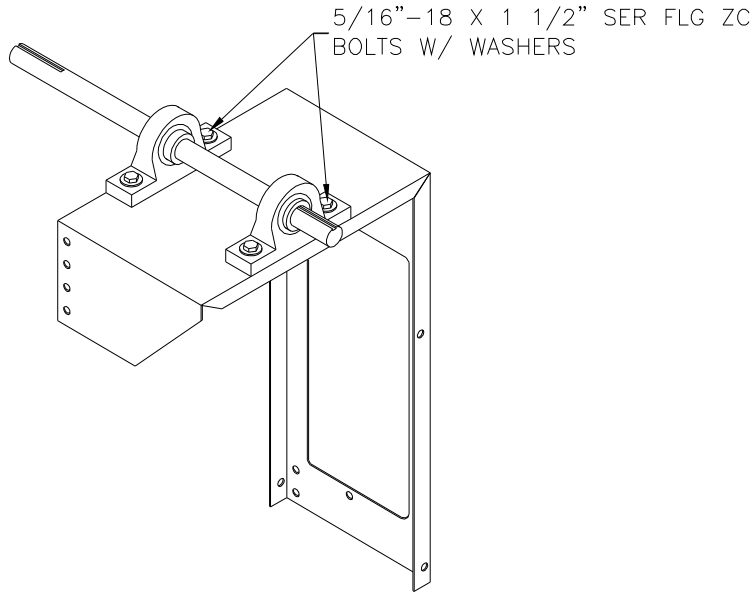

Step 4.

Mount the J-frame to the mounting bars, keeping the shaft at the center. Insert the 5/16" – 18 x 3/4" bolts into the mounting bars so the head of the bolt ends up hidden. Complete the fastening with the 5/16 – 18 nyloc nuts.

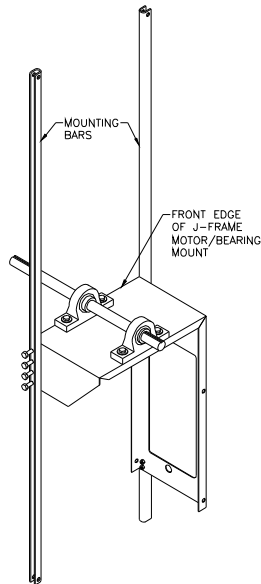

**Step 5.**

Install the fan blade onto the longer end of the shaft. Ensure that the boss of the blade hub goes onto the shaft first and keep the shaft end flush with the blade hub. Install the key into the keyway and tighten the blade setscrew to the shaft using a 5/16" open-end wrench. (If using a cast aluminum blade, equally tighten the 1/4" – 20 setscrews on the face of the "h" bushing; or tighten the tran torque nut). Set this assembly aside.

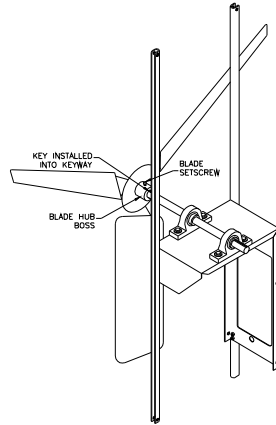

**Step 6.**

Assemble the sides to the top and bottom panel with one #10 x 1/2" square drive sheet metal screw in each corner near the flange. Make sure only one screw is used because the orifice will not install into the box if more are used now. Elevate the crudely assembled box on 6" blocks near the corners.

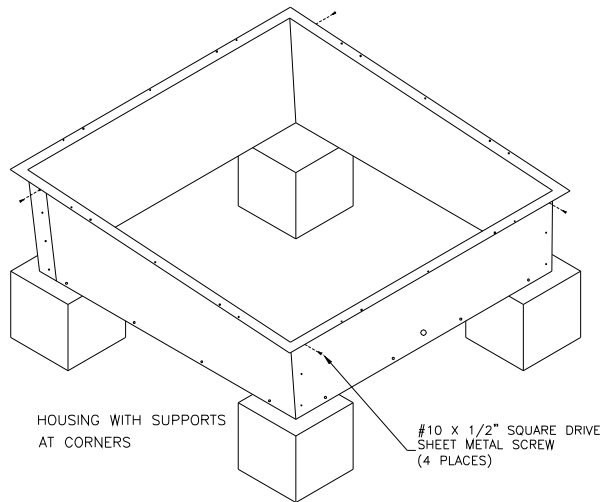

**Step 7.**

Insert the orifice into the box so the throat is farthest away from the box flange. Loosely fasten the orifice to the box using  $\frac{1}{4}$ " - 20 x  $\frac{3}{4}$ " bolts and nyloc nuts from the outside, inward. Complete the fastening of the box together using #10 x  $\frac{1}{2}$ " square drive sheet metal screws. Now you can tighten all the  $\frac{1}{4}$ " - 20 x  $\frac{3}{4}$ " bolts and nuts holding the orifice to the box.

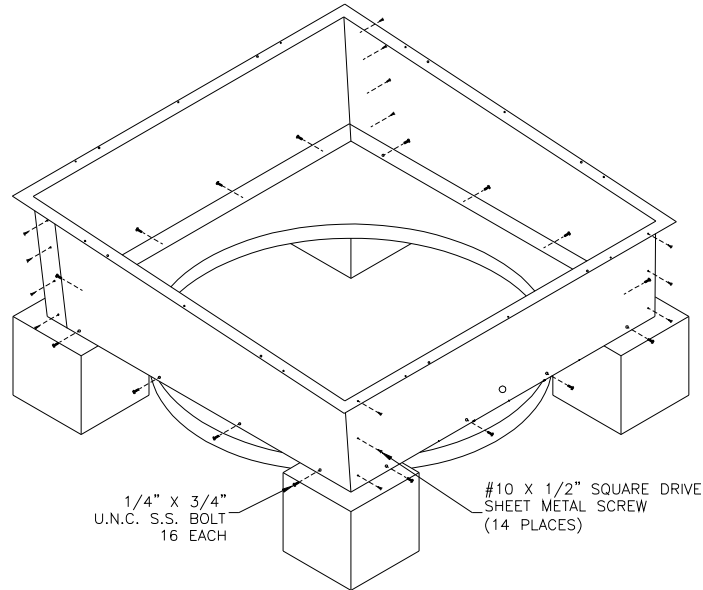

**Step 8.**

Insert the J-frame motor / bearing mount assembly into the fan housing. Make sure the long side of the J-frame motor / bearing mount itself is going down towards the bottom of the fan, and the fan propeller is centered in the orifice. Use  $\frac{5}{16}$ "-18 x  $1\frac{3}{4}$ " bolts & nyloc nuts to fasten to the orifice. Use  $\frac{1}{4}$ "-20 x  $\frac{3}{4}$ " bolt & nut to secure the third leg to the bottom of the lower end of the J plate & to the bottom housing panel.

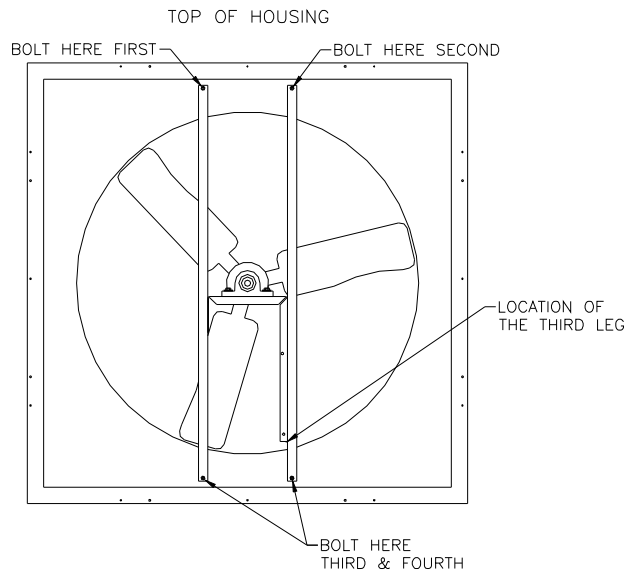

**Step 9.**

Install the large pulley onto the short end of the shaft. The extended hub on the pulley must align flush with the end of the shaft. Install the  $3/16'' \times 1 \ 3/8''$  key into the keyway and tighten the setscrews on the pulley. Take care to ensure that the pulley does not rub on the J-frame motor / bearing mount.

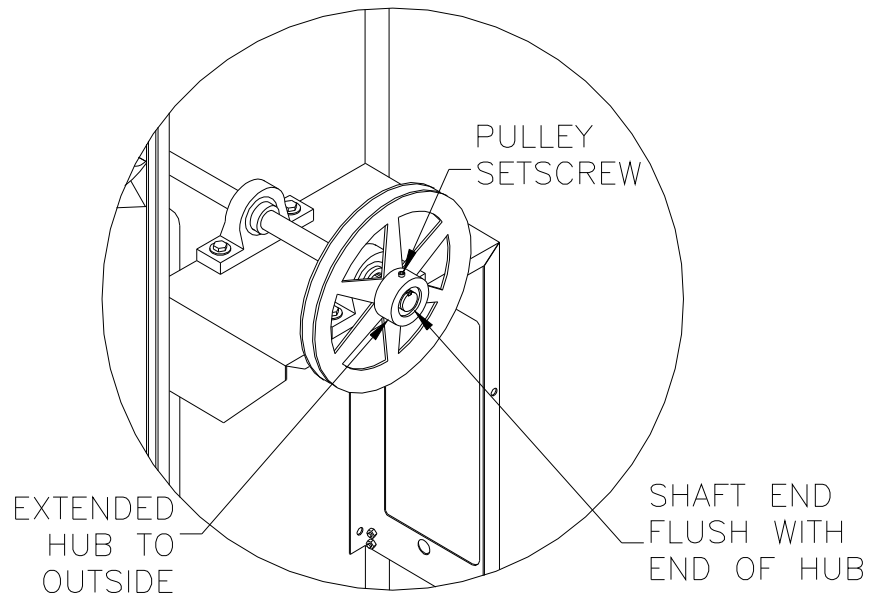

**Step 10.**

Mount the motor to the motor plate. With the motor set on end with the shaft up, the tabs of the motor plate must be on the right. After fastening the motor to the motor plate using two  $5/16'' - 18 \times 3/4''$  bolts and nuts, slide and hold the motor plate to the right and down as much as possible. Tighten the two nuts while holding the motor plate in this position. Insert and tighten the other two  $5/16'' - 18 \times 3/4''$  bolts and nuts to the motor and motor plate assembly.

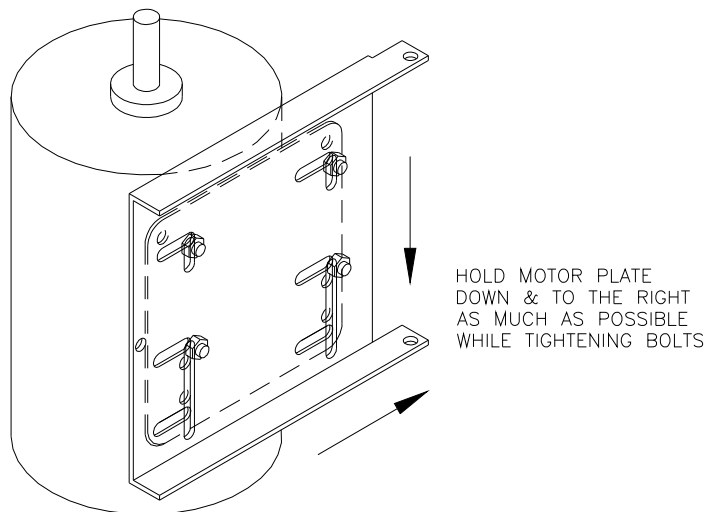

**Step 11.**

Position the motor / motor bearing mount plate assembly onto the J-frame and bolt into place using two 5/16" – 18 x 3/4" bolts and nyloc nuts. Take care not to tighten these bolts to the point of restricting the pivot action of the motor plate.

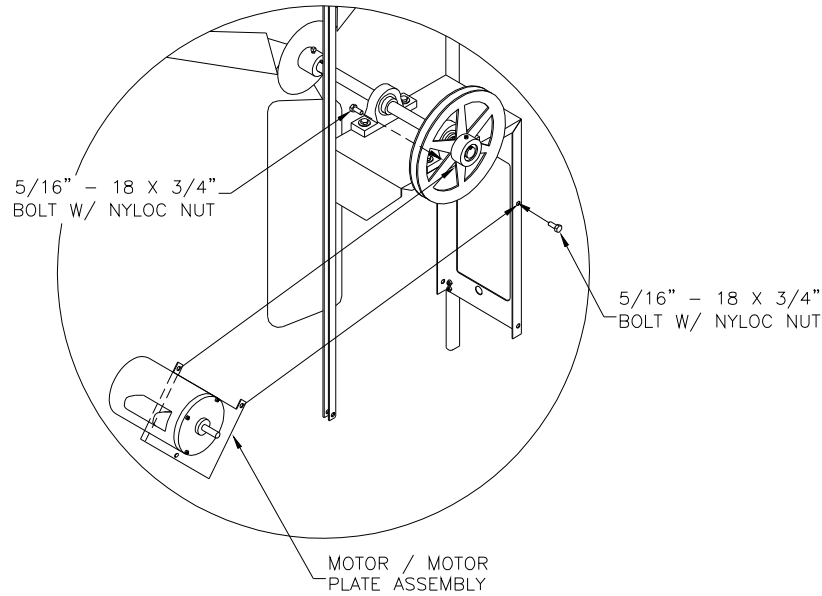

**Step 12.**

Slide the small pulley onto the motor shaft and insert the 3/16" x 1 3/8" key into the keyway. Use a straight edge on the face of the large pulley to align the small pulley. Once the pulleys are aligned properly, use a 5/32" allen wrench to tighten the setscrews on the small pulley.

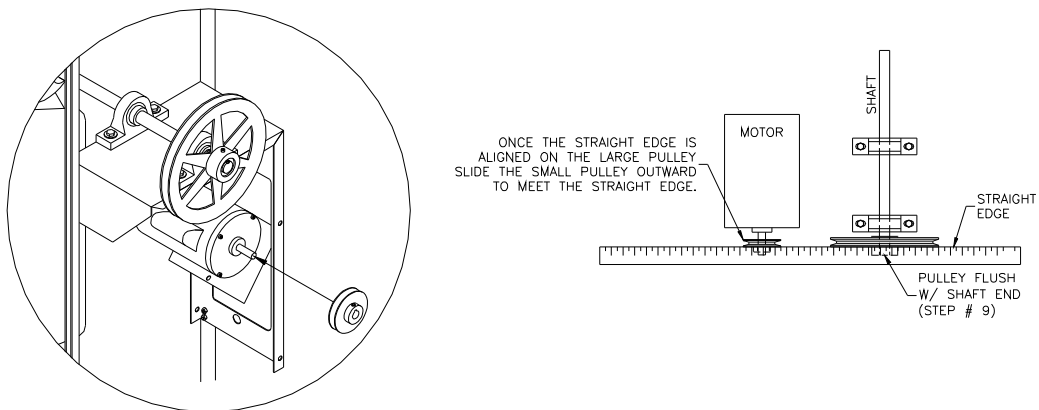

**Step 13.**

Install the v-belt onto the small pulley, then hold the v-belt onto the top of the large pulley and rotate the large pulley clockwise until the v-belt is completely on the large pulley.

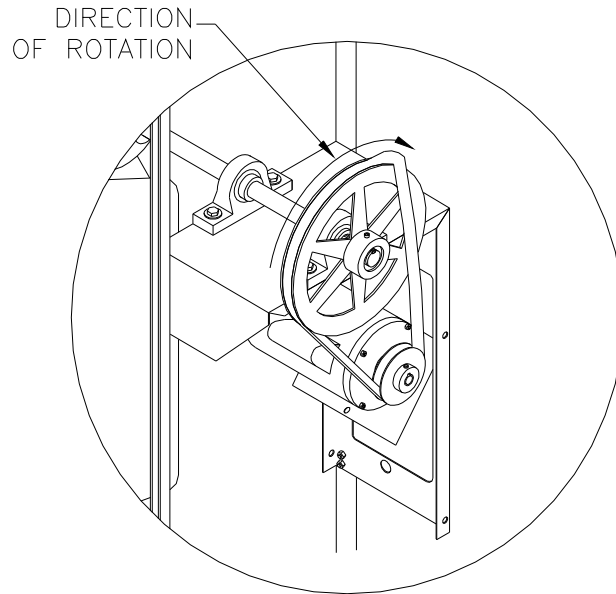

**Step 14.**

Install the belt tension spring onto the J-frame and hook the upper end of the spring to the motor plate. The spring will require to be stretched to hook to the motor plate and care should be taken to avoid injury.

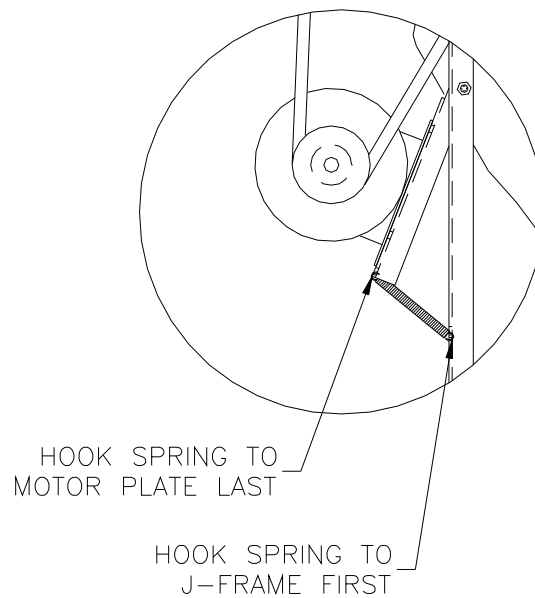



Step 15.

Install the assembled fan into the wall, taking care that the housing slopes downward. Use the shutter clips and self-tapping #10 x 1 1/2" Phillips head screws to fasten the fan to the wall. Take care to screw the shutter clips through the predrilled shutter clip holes in the fan housing. Install the shutter after making sure the shutter vanes open upward and the shutter clips rotate easily. Additional 1/4" x 1 1/2" slotted / hex head lag screws can be used to fasten the fan to the wall if desired. Make sure the lag screws go through the housing flange at a point that they will not interfere with the shutter frame.

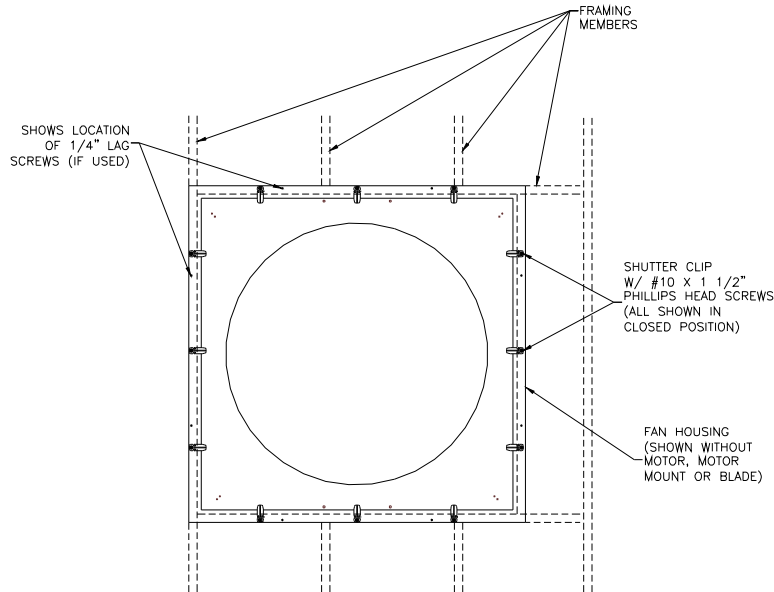

Step 16.

Assemble the discharge cone using steps A thru D instructions below.

Step A.

Assemble the four cone sections together using three 1/4"-20 x 3/4" bolts & nyloc nuts per seam. Do not install the second bolt from the narrowest end of the cone as it will be installed in Step D (Refer to drawing below).

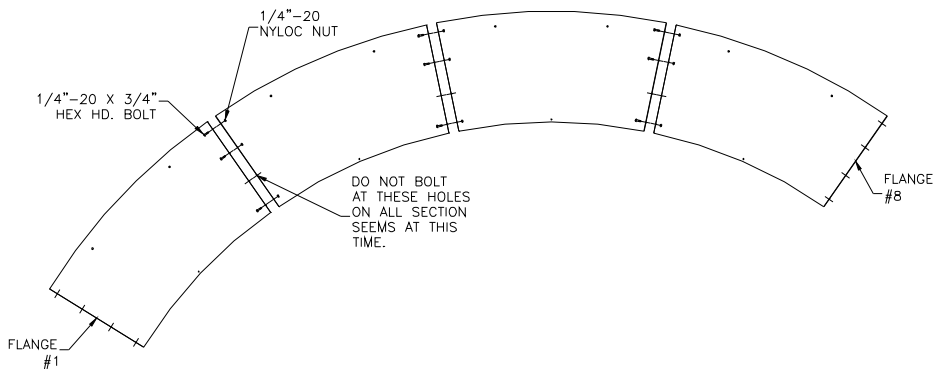

**Step B.**

Form the flat cone sections into a cone by joining flange #1 & flange #8 (refer to drawing above) and using three  $\frac{1}{4}$ "-20 x  $\frac{3}{4}$ " bolts & nyloc nuts, bolt the two flanges together. As in Step #B do not install the second bolt from the narrow end (Refer to drawing below).

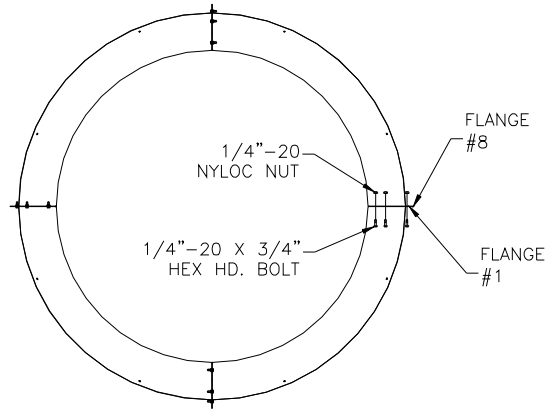

END VIEW  
(FROM SMALL END OF CONE)

**Step C.**

With the formed cone on a flat surface (large diameter up) place the guard screen into the cone (bolt loops up). Align the bolt loops on the guard screen with the bolt holes in the cone and fasten the guard screen in place using  $\frac{1}{4}$ "-20 x  $\frac{3}{4}$ " bolts w/ washers & nyloc nuts with the bolt heads and washers against the guard screen and the nyloc nuts on the outside of the cone assembly. Ensure that the bolt loops on the guard screen are all the way onto the bolts prior to tightening the bolts fully.

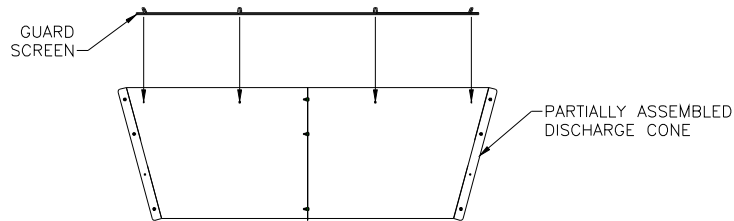

Step D.

Fasten the cone straps to the cone using 1/4"-20 x 3/4" bolts & nyloc nuts. The straps fasten to the cone at the second hole from the narrow end (the holes that were left empty in steps A & B).

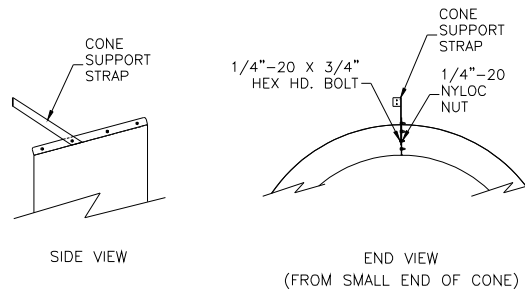

Step 17.

The assembled fan **must** be installed in the wall prior to mounting the cone to the fan.

Slide the narrow end of the cone onto the fan orifice and rotate the cone to align the holes on the cone support straps to the holes on the face of the fan orifice. Fasten the cone support straps to the orifice using two #10 x 1/2" square drive screws per strap. It is recommended to fasten the top two straps first.

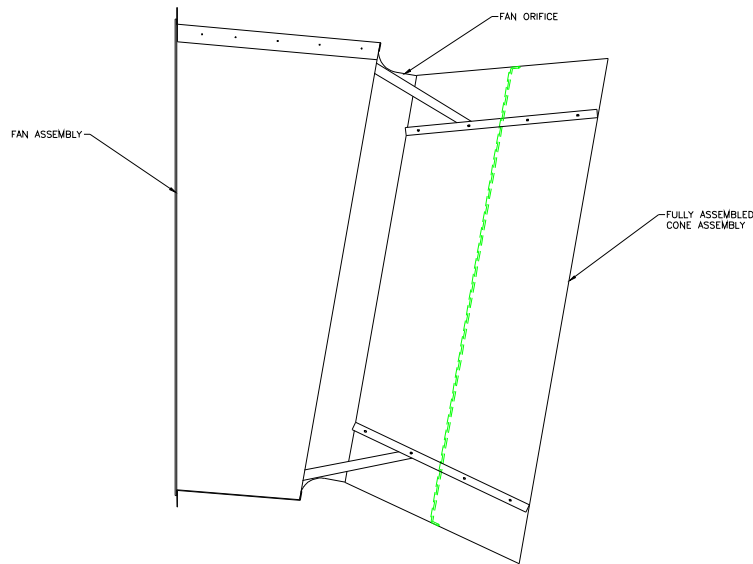

## FAN MAINTENANCE

**CAUTION: Disconnect electrical power before servicing fan.**

**Inspect propeller:** Check to see that the propeller is secure on the shaft and that there are no signs of damage.

**Fasteners:** Retighten nuts and bolts on a quarterly basis.

**Lubrication:** Lubricate the pillow block bearings on a quarterly basis with an NLG1 type grease.

**Clean Fan:**

**Motor:** Remove any dust accumulation from motor using a brush or cloth. (DO NOT USE A PRESSURE WASHER ON THE MOTOR) A clean motor will run cooler and last longer. Check if the motor is secure in its mount.

**Shutter:** Carefully clean dust from shutter vanes and frame so that shutter opens and closes freely. If shutters are extremely dirty you can lose up to 45% of your fan capacity.

**Guard:** Clean any dust or dirt buildup from fan guards using a brush. Dirty guards can also reduce airflow.

**Housing:** Remove dust and dirt accumulations from housing with a pressure washer.

**Inspect Fan Controls:** All controls should be inspected every six months to assure optimum protection of your ventilation system.

- Check all covers for a tight fit.
- Wipe enclosures with a damp rag to remove dirt and dust.
- Clean sensors with a damp rag to remove dirt and dust. Be very careful not to damage sensors.
- **NEVER CLEAN ELECTRICAL EQUIPMENT WITH A POWER WASHER!**

**WIRING DIAGRAM: Be sure power is “OFF” before doing any wiring.** All wiring will be installed in accordance with national, state and local electrical codes. Fans used to ventilate livestock buildings or other rooms where continuous air movement is essential should be connected to individual electrical circuits. For electrical connection requirements, refer to diagram on the motor nameplate or the enclosed wiring diagram. Motors are pre-wired for 230 volts. Motor overload protection should be provided for each fan. A circuit breaker switch or slow blow motor type fuse must be used.

Three phase motors do not include overload protection. Specifications subject to change without notice.

**NOTE: A safety cut-off switch should be located adjacent to the fan.**

**PROPER SHUTTER INSTALLATION:** When installing the shutter, make sure the shutter vanes open upward.

**WARNING If these ventilation products are used to support life in agricultural structures where failure of the system could result in loss or injury, the user must provide an adequate backup and alarm system. The user must accept all risks of such loss or injury due to the possible failure of the ventilation system.**

**CAUTION Do not install fan with moving parts within seven feet of floor or grade level without a guard that complies with OSHA Regulations. Do not use unless electrical wiring complies with all applicable codes. Do not wire without providing for power source disconnect at the fan itself. Do not service except by a qualified maintenance technician and only after disconnecting the power source. Do not install in room where flammable material is stored or flammable vapors might build up. Failure to observe all of these precautions can result in serious injury or death.**

### **SERVICE AND TECHNICAL ASSISTANCE**

Your dealer or the Raydot Service Department will be happy to answer all technical questions which will improve your use of the Galvanized fan series. Be prepared with the model number and necessary information before you place a call to your dealer or Raydot L.L.C. If your fan requires service when the warranty period has expired, please contact your dealer for assistance or return the unit to Raydot L.L.C. for repair.

#### **Inquiries**



*Raydot & ValAir are Divisions of VALCO Companies*

P.O. Box 117  
210 E. Main Street  
Coldwater, OH 45828  
**Ph. 800-998-2526**