

PMC-50" & 48" BELT DRIVE FANS

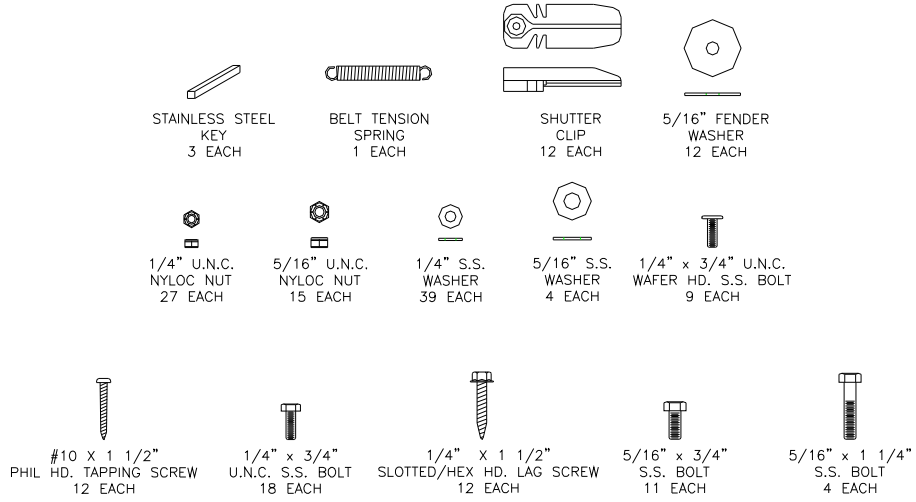

Step 1.

Unpackage and become familiar with all of the fan components and hardware. The legend below will help to familiarize you with the hardware required for this assembly.



Step 2.

Insert the shaft into one of the pillow block bearings, making sure the bearing set screw is toward the middle of the shaft. Keep 2 1/4" of the shaft extended from the race of the bearing. Tighten the setscrews to hold this bearing in position. Slide the other bearing onto the other end of the shaft, making sure the setscrew is toward the middle of the shaft. Do not tighten the setscrew at this time.

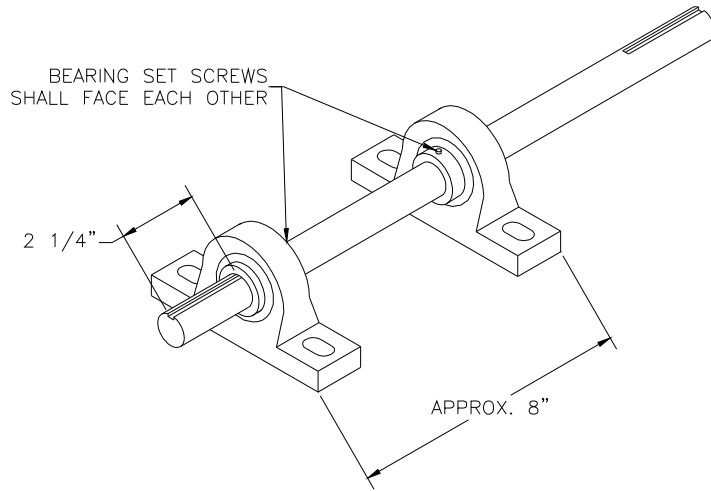

Step 3.

Mount the bearing / shaft subassembly to the motor mount cross bar. Keeping the bearings centered on the cross bar, insert one of the 5/16" X 1 1/4" s.s. bolts, with heads up, into each of the bearings holes on the side of the bearing opposite of the two spring holes (refer to drawing below). The long end of the shaft must be on the side of the cross bar with the corners cut off.

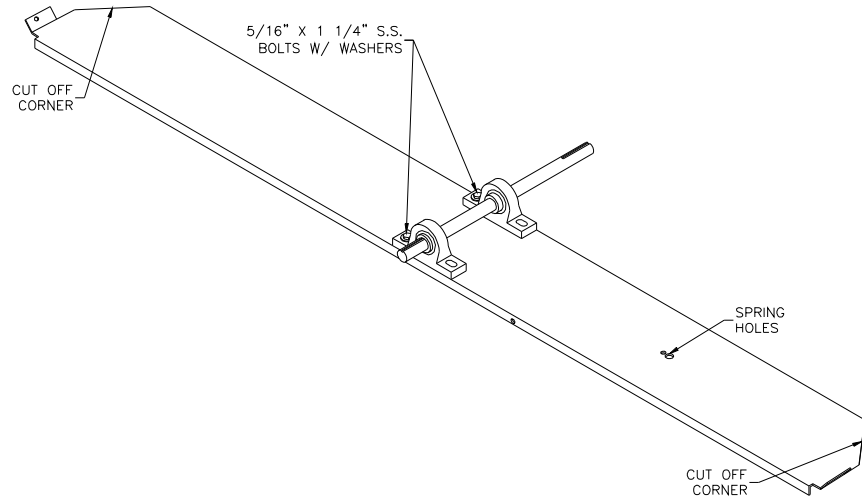

Step 4.

Mount the motor mount support to the cross bar. The straight edge of the support shall align with the front edge of the cross bar. Using two 5/16" X 1 1/4" s.s. bolts w/ 5/16" nuts and washers attach the support to the under side of the cross bar through the bearings and other two holes in the crossbar.

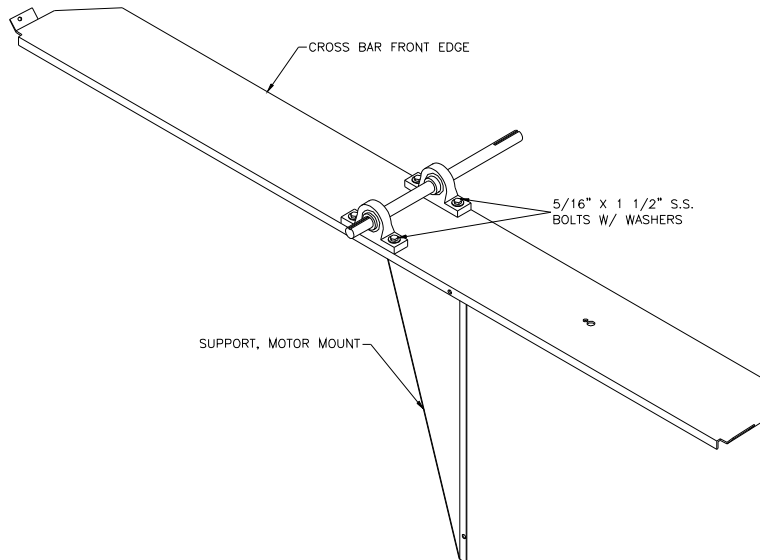

Step 5.

As you tighten the bearings to the cross bar, ensure that the shaft is able to turn freely in the pillow block bearings.

Step 6.

Tighten the bearing set screws using an 1/8" allen wrench.

Step 7.

Install the fan blade onto the longer end of the shaft. Ensure that the boss on the blade hub goes onto the shaft first and keep the shaft end flush with the blade hub. Install the key into the key way and tighten the blade set screw to the shaft using a 5/16" opened end wrench. (If using a cast aluminum blade, equally tighten the 1/4" – 20 screws on the face of the "H" bushing.)

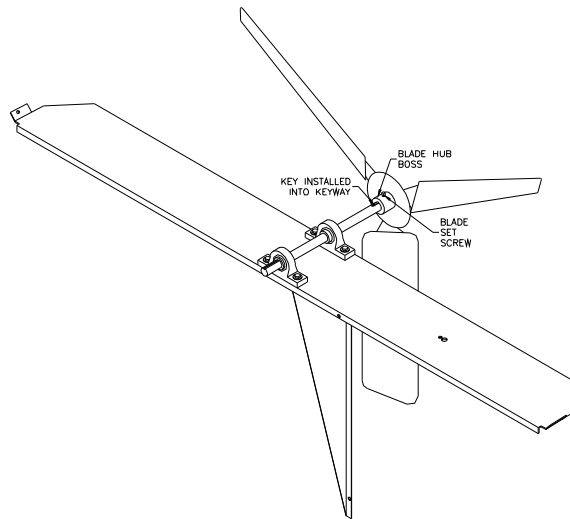

Step 8.

With the round orifice facing down, support the housing at the four corners so that the orifice is held about 4" off the floor/ground. This must be done to allow the motor mount assembly to rest on the fan housing and be fastened in place. Position the assembled motor mount into the housing so the support is at the bottom of the housing. Using 5/16" x 3/4" bolts with nuts (and fender washers where noted) bolt the motor mount support to the housing (bolt heads shall be on the outside of the housing). Bolt the cross bar motor mount to the housing (again keep the bolt heads on the outside of the housing). Tighten the bolts on the motor mount / housing, ensuring that the fan blade is centered in the orifice. The bearing bolts may be loosened to center the blade and retightened if needed.

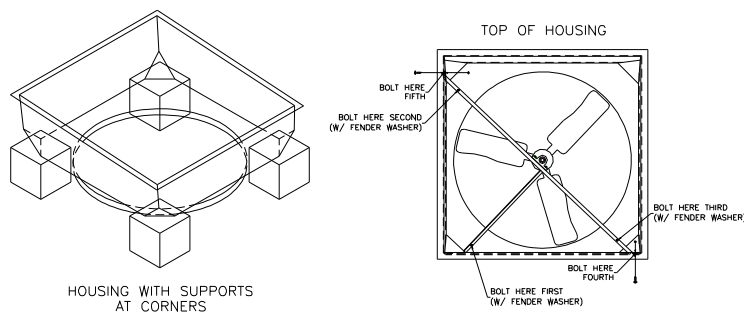

Step 9.

Install the large pulley onto the short end of the shaft. The extended hub on the pulley must align flush with the end of the shaft. Install the 3/16" x 1 3/8" key into the keyway and tighten the setscrews on the pulley. Take care to ensure that the pulley does not rub on the cross bar.

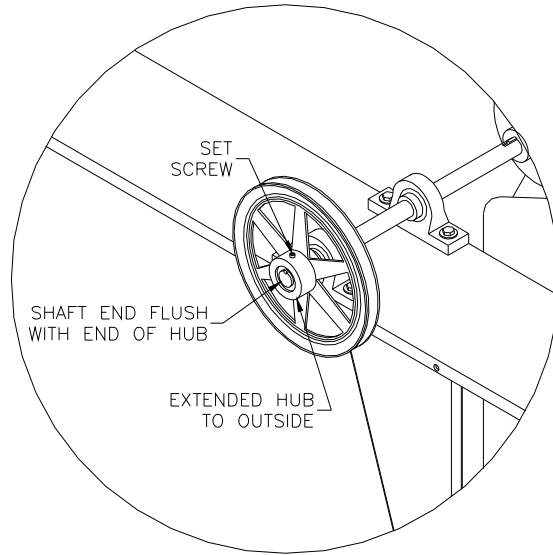

Step 10.

Mount the motor to the motor plate. With the motor set on end with the shaft up, the tabs on the motor plate must be on the right. After fastening the motor to the motor plate using two 5/16" x 3/4" bolts and nuts, slide and hold the motor plate to the right and up as much as possible. Tighten the two nuts while holding the motor plate in this position. Insert and tighten the other two 5/16" x 3/4" bolts and nuts to the motor and motor plate assembly.

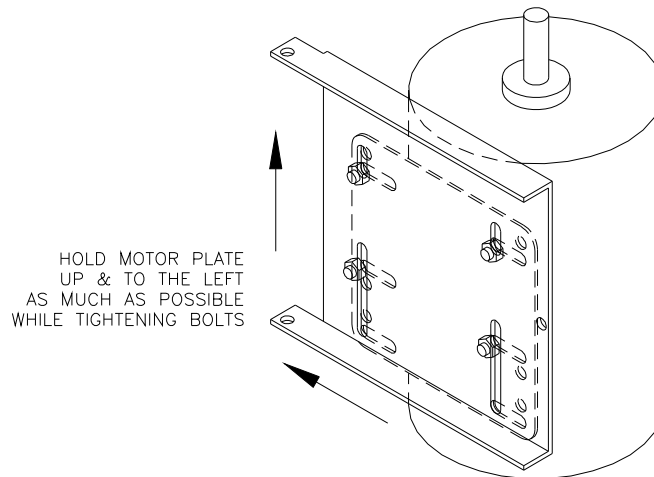

Step 11.

Position the motor/motor plate assembly onto the cross bar and bolt into place using 2 – 5/16" x 3/4" S.S. bolts and nyloc nuts. Take care not to tighten these bolts to the point of restricting the pivot action of the motor plate.

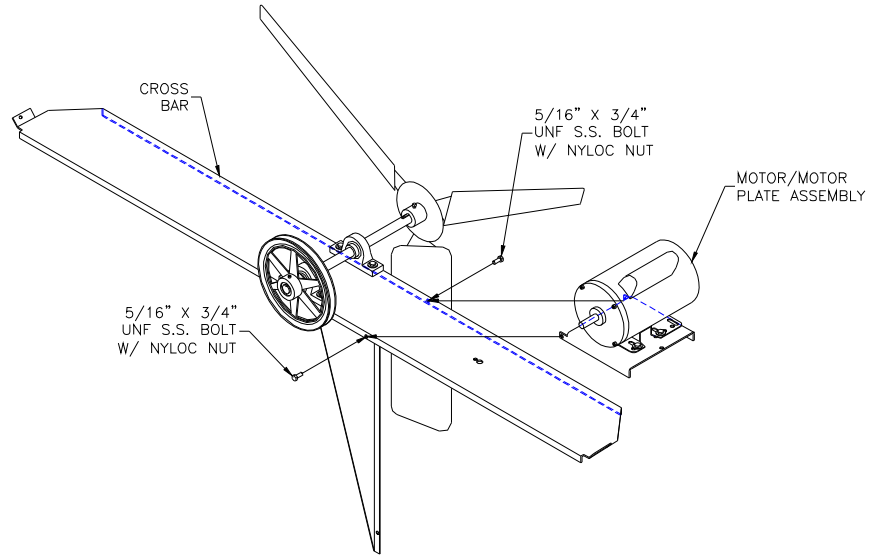

Step 12.

Slide the small pulley onto the motor shaft and insert the 3/16" x 1 3/8" key into the keyway. Use a straight edge on the face of the large pulley to align the small pulley. Once the pulleys are aligned properly, using a 5/32" allen wrench tighten the setscrews on the small pulley.

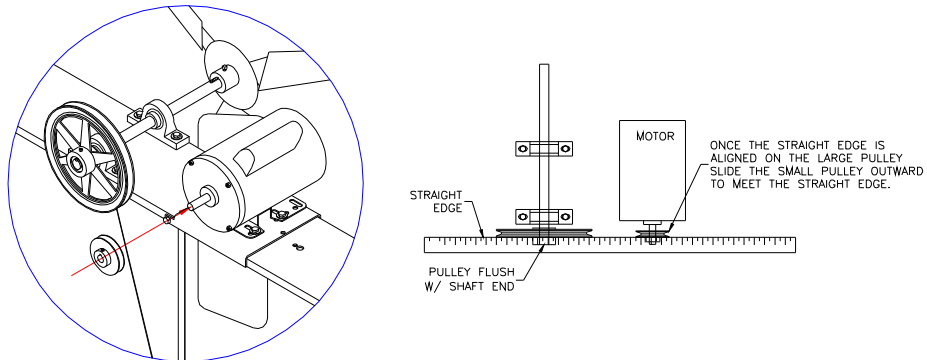

Step 13.

Install the v-belt onto the small pulley, then hold the v-belt onto the top of the large pulley and rotate the large pulley clockwise until the v-belt is completely on the large pulley.

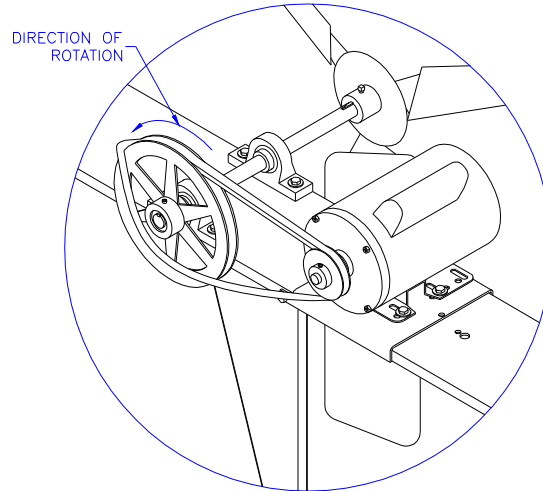

Step 14.

Install the belt tension spring onto the cross bar and hook the upper end to the motor plate. The spring will require to be stretched to hook to the motor plate and care should be taken to avoid injury.

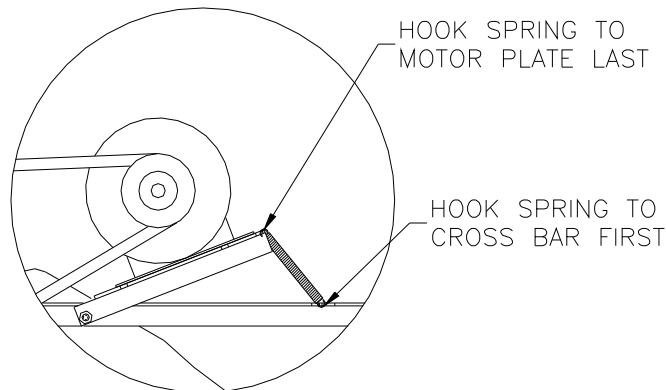

Step 15.

Install the assembled fan into the wall, taking care that the housing slopes downward. Use the shutter clips and the self-tapping #10 x 1 1/2" phillips head screws to fasten the fan to the wall (refer to drawing on the following page for framing detail). Take care to screw the shutter clips through the predrilled shutter clip holes in the fan housing. Install the shutter after making sure the shutter vanes open upward and shutter clips rotate easily. Additional 1/4" x 1 1/2" slotted/hex head lag screws can be used to fasten the fan to the wall if desired. Make sure the lag screws go through the housing flange at a point they will not interfere with the shutter frame.

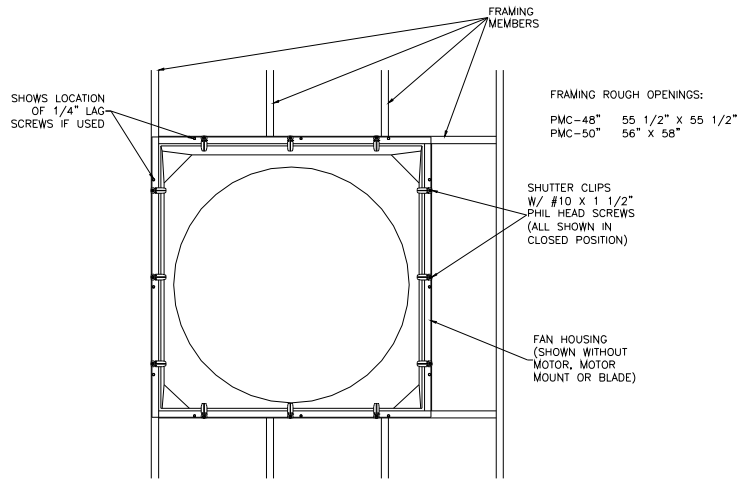

Step 16.

Assemble the discharge cone using four, 1/4" x 3/4" bolts and nuts with washer on each standing seam.

Step 17.

Mount the assembled cone onto the fan housing (this shall be done after the fan housing has been installed into the wall). Use the remaining nine 1/4" x 3/4" bolts with nuts & washers to fasten the cone to the fan housing. The bolts must be inserted from the inside of the fan orifice through the cone so that the washer and nyloc nut are on the outside. This is very important that the bolt head is the only thing inside of the orifice to reduce the risk of the fan blade hitting anything.

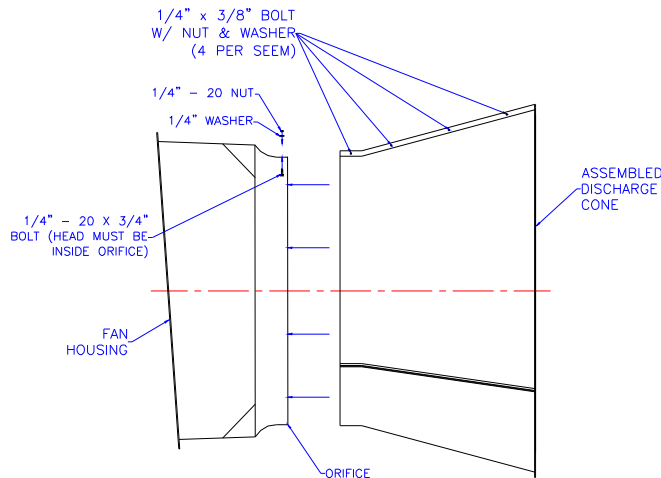

Step 18.

After the cone has been mounted to the fan housing, install the guard screen into the discharge cone using 6 1/4"-20 x 3/4" bolts, washers and nyloc nuts. Note that the bolt head and washer shall be to the inside, against the guard screen loop and the nyloc nut shall be on the outside of the cone.

Step 19.

Install the shutter onto the fan housing on the inside of the building. Use the shutter clips and the self-tapping #10 x 1 1/2" phillips head screws to mount the shutter. Take care to screw the shutter clips only through the fan housing and not through the shutter itself. When installing the shutter, make sure the shutter vanes open upward.

FAN MAINTENANCE

CAUTION: Disconnect electrical power before servicing fan.

Inspect propeller: Check to see that the propeller is secure on the shaft and that there are no signs of damage.

Fasteners: Retighten nuts and bolts on a quarterly basis.

Lubrication: Lubricate the pillow block bearings on a quarterly basis with a NLG1 type grease.

Clean Fan:

Motor: Remove any dust accumulation from motor using a brush or cloth. (DO NOT USE A PRESSURE WASHER ON THE MOTOR) A clean motor will run cooler and last longer. Check if the motor is secure in its mount.

Shutter: Carefully clean dust from shutter vanes and frame so that shutter opens and closes freely. If shutters are extremely dirty you can lose up to 45% of your fan capacity.

Guard: Clean any dust or dirt buildup from fan guards using a brush. Dirty guards can also reduce airflow.

Housing: Remove dust and dirt accumulations from housing with a pressure washer.

Inspect Fan Controls: All controls should be inspected every six months to assure optimum protection of your ventilation system.

- Check all covers for a tight fit.
- Wipe enclosures with a damp rag to remove dirt and dust.
- Clean sensors with a damp rag to remove dirt and dust. Be very careful not to damage sensors.
- **NEVER CLEAN ELECTRICAL EQUIPMENT WITH A POWER WASHER!**

WIRING DIAGRAM: Be sure power is “OFF” before doing any wiring. All wiring will be installed in accordance with national, state and local electrical codes. Fans used to ventilate livestock buildings or other rooms where continuous air movement is essential should be connected to individual electrical circuits. For electrical connection requirements, refer to diagram on the motor nameplate or the enclosed wiring diagram. Motors are pre-wired for 230 volts. Motor overload protection should be provided for each fan. A circuit breaker switch or slow blow motor type fuse must be used.

Three phase motors do not include overload protection. Specifications subject to change without notice.

NOTE: A safety cut-off switch should be located adjacent to the fan.

PROPER SHUTTER INSTALLATION: When installing the shutter, make sure the shutter vanes open upward.

WARNING If these ventilation products are used to support life in agricultural structures where failure of the system could result in loss or injury, the user must provide an adequate backup and alarm system. The user must accept all risks of such loss or injury due to the possible failure of the ventilation system.

CAUTION Do not install fan with moving parts within seven feet of floor or grade level without a guard that complies with OSHA Regulations. Do not use unless electrical wiring complies with all applicable codes. Do not wire without providing for power source disconnect at the fan itself. Do not service except by a qualified maintenance technician and only after disconnecting the power source. Do not install in room where flammable material is stored or flammable vapors might build up. Failure to observe all of these precautions can result in serious injury or death.

SERVICE AND TECHNICAL ASSISTANCE

Your dealer or the Raydot Service Department will be happy to answer all technical questions which will improve your use of the Power Miser series fan. Be prepared with the model number and necessary information before you place a call to your dealer or Raydot L.L.C. If your fan requires service when the warranty period has expired, please contact your dealer for assistance or return the unit to Raydot L.L.C. for repair.

Inquiries



Raydot & ValAir are Divisions of VALCO Companies

P.O. Box 117
210 E. Main Street
Coldwater, OH 45828

Ph. 800-998-2526