

Setting DIP Switches

The controller assigns devices (input sensors or output channels) by station and channel number. **The host controller is always station address number 1.** Begin numbering your expansion stations from number 2.

The switches ADDRESS SELECT 1, 2, 4, and 8 are used to select an address number for the expansion station. Each station must be given a unique number. The controller uses these address numbers to communicate with specific stations. You will need to know the station number when you designate installed devices using the main controller’s System & Control Device Set-Up menu.

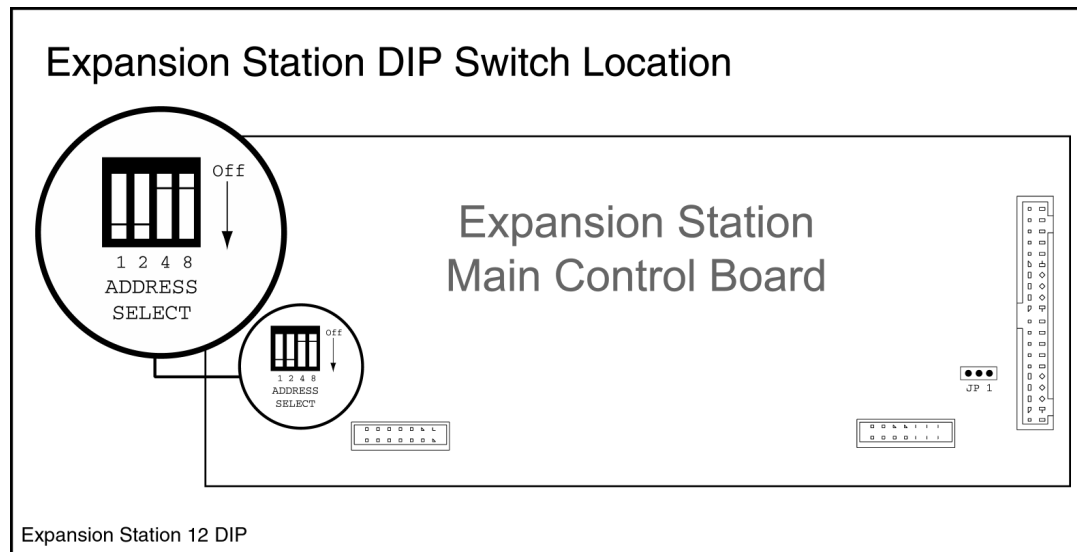

Note: Actual DIP Switch block orientation and labeling may vary from the example shown.

The table below shows the switch settings for each possible address number. For example, to assign an address number of 2, set the switches as follows: 1 - on, 2 - off, 4 - off, 8 - off.

When the switch positions are changed, remove and re-apply power to the board to reset it (or press the reset switch).

	Station Address Number															
	1 (host)	2	3	4	5	6	7	8	9	10	11	12	13	14	15	16
Switch 1	Off	On	Off	On	Off	On	Off	On	Off	On	Off	On	Off	On	Off	On
Switch 2	Off	Off	On	On	Off	Off	On	On	Off	Off	On	On	Off	Off	On	On
Switch 4	Off	Off	Off	Off	On	On	On	On	Off	Off	Off	Off	On	On	On	On
Switch 8	Off	Off	Off	Off	Off	Off	Off	Off	On	On	On	On	On	On	On	On

Termination

If the expansion station is at the end of the communications chain (or if it is connected to a single controller) the terminate jumper (JP1) located inside the front cover by the ribbon cable should be installed across pins 1 and 2 (counting left to right).

If the expansion station is not at the end of the communications chain, the terminate jumper should be installed across pins 2 and 3.

You may also need to terminate or un-terminate your controller. Refer to the Installation manual for more information about termination for the controller.

Front Panel LEDs

- **Power** - Illuminates when power is applied to the station.
- **Transmit / Receive** - These illuminate or flicker on and off when the station is communicating with the controller.
- **Output Channel LEDs** - These illuminate when an output channel is turned on either manually or by the controller.

Specifications

Fuses:	Power Supply Input: 2.5 Amp 250VAC (5 x 20 mm) fast-acting interrupting type (Littelfuse® 216 02.5 or equivalent) Output Channel: 20 Amp 3AB ceramic body slow-acting type (Bussmann® MDA-20 or equivalent 0.25 x 1.25”)
Power Input:	90-265VAC 50/60 Hz universal power supply, 1.5A maximum. <i>Maximum torque on power input terminal screws is 8 inch-pounds.</i>
Output:	Normally Open relay 120VAC, 1HP / 240VAC, 1.5HP 16A 120/240VAC, 5.46A tungsten rating at 240V, 8.3A tungsten rating at 120V, 144A maximum total for all channels combined
Alarm Output:	120VAC/240VAC, 3A general purpose, NO/NC connection
Sensor Inputs:	10 analog and 4 digital
Environmental:	Type 4, 4X, 12, 13 IP65
Dimensions:	Width: Approximately 10.5 inches 26.7 centimeters Height: Approximately 12.5 inches 31.8 centimeters Depth: Approximately 6.25 inches 15.9 centimeters

ENVIRONMENTAL PRODUCTS WARRANTY

PLEASE READ THIS WARRANTY CAREFULLY. IF YOU (THE PURCHASER) DO NOT AGREE WITH THE WARRANTY LIMITATIONS OR ITS TERMS AND CONDITIONS, PROMPTLY RETURN THIS PRODUCT, UNUSED, TO THE PLACE WHERE YOU OBTAINED IT FOR A FULL REFUND.

LIMITED WARRANTY: Blue Earth Research, LLC. (hereinafter BEaR) warrants this Product to be free from defects in material and workmanship and agrees to repair or replace any Product which proves defective under these terms and conditions.

IMPROVEMENTS: BEaR reserves the right to alter or improve this Product without notice and without incurring obligation to alter or improve existing Products.

LENGTH OF WARRANTY: This Product is warranted for a period of twelve (12) months from the date of installation. Sensors are warranted for a period of twelve (12) months from the date of manufacture or six (6) months from the date of installation.

WHO IS PROTECTED: This warranty is valid only for the original installation and is not transferable.

WHAT IS NOT COVERED: The following are not covered by this warranty:

- 1) Damage, deterioration or malfunction resulting from, but not limited to: power fluctuations or surges, accident, misuse, abuse, neglect, fire, water, corrosion, lightning or other acts of nature, improper storage, unauthorized Product repair or modification, damage in shipment, removal or installation of this Product, or any other cause not related to a Product defect.
- 2) Cartons, batteries, and other accessories used in connection with this Product.
- 3) Product returned without customer identification.
- 4) Service required as a result of third party components.

WHAT IS NOT REIMBURSABLE: The following items are not reimbursable:

- 1) Troubleshooting, removal or installation charges.
- 2) Setup, calibration, adjustment or maintenance of this Product.
- 3) Shipping and insurance charges for returning this Product to BEaR.
- 4) Customer training.
- 5) Travel expenses.

HOW TO GET WARRANTY SERVICE: You have the option of having your dealer replace/exchange any defective Product or returning this Product freight prepaid and insured to BEaR. All Product returned to BEaR must have customer identification attached.

CONSUMER CAUTION: System configuration, software, operator control of the system, and the application, among other things, will affect this Product's performance. While this Product is considered compatible with its intended purpose, the specific functional implementation by the customers of this Product may vary. The responsibility for using this Product and programming it to achieve the intended purpose, is the sole responsibility of the Purchaser.

LIMITATION OF DAMAGES AND IMPLIED WARRANTIES:

BEaR'S SOLE LIABILITY UNDER THIS WARRANTY AND PURCHASER'S EXCLUSIVE REMEDY FOR ANY DEFECTIVE PRODUCT, IS LIMITED TO THE REPAIR OR REPLACEMENT OF THIS PRODUCT, AT BEaR'S OPTION. IN THE EVENT BEaR CANNOT DO EITHER, THEN THE PURCHASER'S ALTERNATIVE EXCLUSIVE REMEDY SHALL BE A REFUND OF THE PURCHASE PRICE IN EXCHANGE FOR THE RETURN OF THE DEFECTIVE PRODUCT TO THE PLACE OF PURCHASE. BEaR SHALL NOT BE LIABLE FOR:

- 1) DAMAGE TO OTHER PROPERTY CAUSED BY ANY DEFECTS IN THIS PRODUCT, INCLUDING BUT NOT LIMITED TO DAMAGES BASED UPON INCONVENIENCE, LOSS OF USE OF THIS PRODUCT, LOSS OF TIME OR DATA, OR ANY OTHER LOSS.
- 2) ANY OTHER DAMAGES, WHETHER INCIDENTAL, CONSEQUENTIAL, OR OTHERWISE FROM USE OR INABILITY TO USE THIS PRODUCT.

THIS WARRANTY IS EXCLUSIVE AND IS IN LIEU OF ALL OTHER WARRANTIES, EXPRESS OR IMPLIED, INCLUDING, BUT NOT LIMITED TO, THE IMPLIED WARRANTIES OF MERCHANTABILITY OR FITNESS FOR A PARTICULAR PURPOSE. SOME STATES DO NOT ALLOW THE EXCLUSION OF IMPLIED WARRANTIES OR THE LIMITATION OR EXCLUSION OF LIABILITY FOR INCIDENTAL OR CONSEQUENTIAL DAMAGES. THEREFORE, THE ABOVE EXCLUSIONS OR LIMITATIONS MAY NOT APPLY TO YOU.

THIS WARRANTY GIVES YOU SPECIFIC LEGAL RIGHTS, AND YOU MAY ALSO HAVE OTHER RIGHTS WHICH VARY FROM STATE TO STATE IN THE UNITED STATES OF AMERICA.

PURCHASER AGREES THAT THE SALE OF THIS PRODUCT BEARS A REASONABLE RELATIONSHIP TO THE STATE OF MINNESOTA AND THE LAWS OF THE STATE OF MINNESOTA SHALL GOVERN THE VALIDITY, CONSTRUCTION AND ENFORCEABILITY OF THIS WARRANTY, WITHOUT GIVING EFFECT TO THE CONFLICT OF LAWS PRINCIPLES THEREOF.

THE PURCHASER OF THIS PRODUCT AGREES THAT ALL CLAIMS BROUGHT IN RESPECT OF THIS WARRANTY SHALL BE BROUGHT IN A COURT LOCATED IN THE STATE OF MINNESOTA.