

MANUAL ECS-5C



Installation / User's Guide

ATTENTION ELECTRICIAN
SEE WIRING DETAILS ON PAGES A-3 TO A-5 AND
ADDITIONAL INFORMATION IN SECTION B

WIRING DIAGRAM

SECTION A

INSTALLATION GUIDE

SECTION B

USER'S GUIDE

SECTION C

INDEX / WARRANTY

SECTION D

ECS-5C WIRING DIAGRAM**WARNINGS AND PRECAUTIONS**

Although the manufacturer has made every effort to ensure the accuracy of the information contained herein, this document is subject to change without notice due to ongoing product development.

WARNINGS AND PRECAUTIONS

Equipment, probe failure, blown fuses and/or tripped breakers may prove harmful to the contents of the building. Therefore it is strongly recommended to install backup devices and alarm or warning devices. Spare equipment should also be available at the owner's site. Equipment manufactured by the manufacturer is protected against normal line surges. High surges caused by thunderstorms or power supply equipment may damage this equipment. For added security against line voltage surges it is recommended that surge and noise suppression devices be installed at the electrical distribution panel. Use of shielded cable for probes is recommended for protection against lightning. These devices are available from most electrical supply distributors.

RECOMMENDATIONS

The manufacturer recommends that all installation procedures described herein be performed by a qualified electrician or installation technician. Furthermore the manufacturer recommends testing all the functions and equipment connected to the ECS-5C, including the alarm system and backup devices, after installation, after changes to the installation and every month after that.

Fuse verification and replacement, as well as the proper setting of control values shall be the responsibility of the owner of this equipment.

WIRING DIAGRAM ECS-5C SECTION A

ECS-5C WIRING DIAGRAM

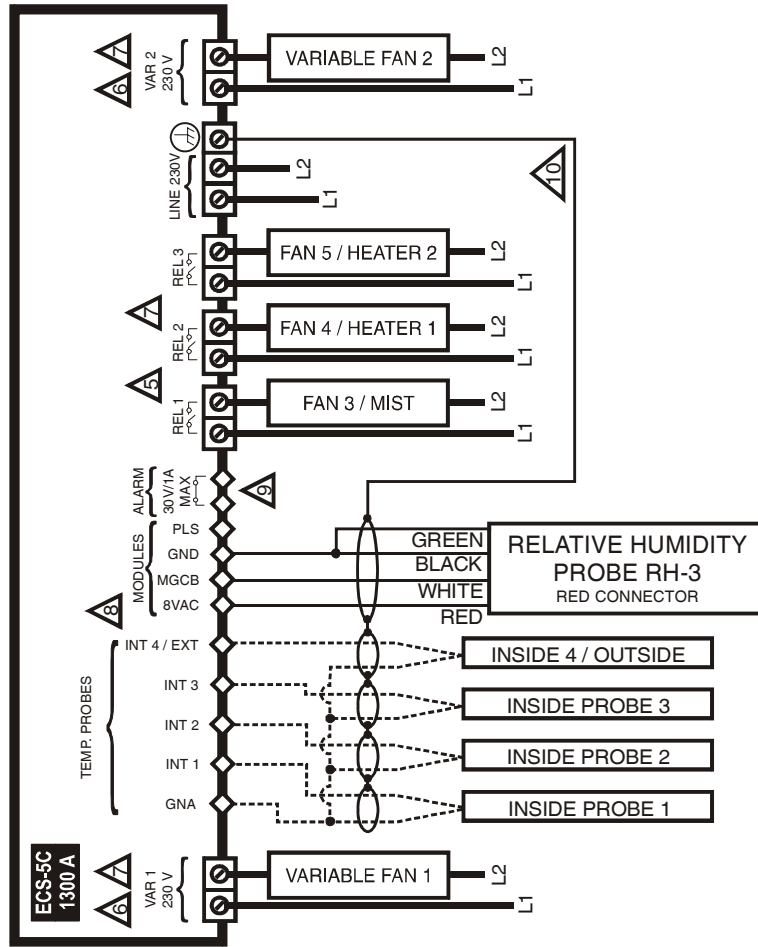

Varifan[®]

WIRING DIAGRAM	
29/09/09	C100V02V0
WIR	REV 0

SEE NOTES ON NEXT PAGE

ECS-5C

Electrician's notes wiring tips and hints (see guide for details)

1 ----- (PROBE WIRING) SHIELDED WIRE AWG #22 WITH 16/30 STRANDING, 500ft (150m) MAXIMUM LENGTH. (Ex.: DECA 73-310)
For other probe, refer to specific probe manual for appropriate maximum length and wire size or use AWG #22, 500ft (150m) MAXIMUM LENGTH.

2 ————— (COMMUNICATION WIRING) SHIELDED LOW CAPACITANCE WIRE, (Capacitance between conductors @ 1Khz = 24pF/ft), TWISTED PAIR (8 twist/ft), AWG #22, 820ft (250m) MAX LENGTH. (Ex.: BELDEN 8761)

3 ————— HIGH VOLTAGE WIRE INSTALLED ACCORDING TO LOCAL WIRING CODE.

4 INSTALL LOW VOLTAGE WIRES (PROBES, COMPUTER LINK OR POTENTIOMETER WIRES) AT LEAST 12in. (30cm) AWAY FROM HIGH VOLTAGE WIRES (120/230VAC, 24VDC). ALWAYS CROSS HIGH AND LOW VOLTAGE WIRES AT A 90-DEGREE ANGLE.



RELAYS: 10A @ 240VAC RESISTIVE, MOTOR 1HP @ 240VAC, 1/2HP @ 120VAC AT EACH OUTPUT.



THE CURRENT SHALL NOT EXCEED 8A AT EACH OUTPUT (VARIABLE STAGE). THOSE OUTPUTS REQUIRE THE SAME PHASE AND SAME VOLTAGE AS THE ECS-5C OPERATES.



MAXIMUM 2 WIRES OF SAME SIZE PER BLACK TERMINAL, NO BIGGER THAN AWG #12, NO SMALLER THAN AWG #22.



1 WIRE ONLY PER GREEN TERMINAL. USE WIRE CONNECTOR IF YOU WANT TO CONNECT MORE THAN 1 WIRE, NO BIGGER THAN AWG #12, NO SMALLER THAN AWG #28.



CHECK INSTALLATION GUIDE FOR ALARM WIRING.



USE SHIELD FOR SHIELDING PURPOSE ONLY. CONNECT THE SHIELD TO GROUND PLATE⊕. NEVER LEAVE THE SHIELD UNCONNECTED AT BOTH ENDS. NEVER CONNECT BOTH ENDS OF THE SHIELD TO GROUND PLATE⊕. THE USE OF A SHIELD FOR ALL PROBES IS **MANDATORY**.

INSTALLATION ECS-5C SECTION B

This section will inform the electrician on proper wiring and installation procedures for the ECS-5C.

The manufacturer recommends that the following installation instructions to be followed as closely as possible, and that all work be performed by a certified electrician. Failure to do so may void the warranty.

Unpacking

Unpack the ECS-5C and inspect contents for damage. Should the contents appear to be damaged, contact your local distributor to return the material.

The package should contain the following standard items:

- 1 ECS-5C control
- 4 Brackets / 4 screws
- 1 2004-10K inside temperature probe
- 1 Installation / User's Guide

Mounting Hardware Required

This is the list of the mounting hardware needed, which is not included with the product:

- Shielded two-wire cable, AWG #22 (to extend probes).
- Shielded two-wire twisted pair cable, AWG #22 to #24 (used for communication) see electrician note for capacitance selection.
- 4 screws (to hang the unit onto the wall).
- Screwdrivers.
- Soldering iron kit or approved sealed connectors.
- Drill and hole saw kit

General installation guidelines

ECS-5C Control

- It is recommended to install the unit in a hallway to limit the ECS-5C exposure to noxious gases.
- In order to avoid condensation problems inside the controller, it is recommended to install the ECS-5C on an inside wall. If it is not possible, use spacers to have an air gap between the wall and the ECS-5C.
- It is required to install the ECS-5C side up with the cable entry holes facing down.
- The enclosure is watertight, but do not spray water or immerse the ECS-5C in water. Cover it carefully with plastic when cleaning the room.
- The ECS-5C should be installed in easy access location but away from damaging elements (heat, cold, water, direct sunlight, ...).
- Do not drill the face, the side, the top or the rear of the control.
- Do not install the ECS-5C control near high voltage equipment, power supply or transformer.

Electrical Cables

- All electrical cables must be installed according to local wiring codes.
- All cable shields must be connected to the ECS-5C power ground only, except for the cable connected to the optional PC interface. The shield is needed to protect the ECS-5C and the modules against any electromagnetic interference generated by lightning or nearby operating machinery.
- Never use the shield as a conductor.
- Connect only one end of the shield to the ground of the ECS-5C.
- Use separate conduit for the low voltage cables (communication and probes) and the high voltage cables. There must be at least 1 foot (30 cm) between low voltage and high voltage conduits.
- If a low-voltage cable has to cross over a high voltage cable, make this crossing at 90°.
- All cable connections must be soldered or done with approved sealed connectors.
- Probe cables must be 500' (150m) or less.
- Communication cables must be 820' (250m) or less.
- It is prohibited to use overhead cables outside the building.

Electrical Power

- Protection from electrical surge should be included in the planning of each installation.
- The VAR1 and VAR2 outputs require the same phase and same voltage as the ECS-5C to operate.
- It is strongly recommended to have a backup power source to ensure life-sustaining conditions in case of power failure (see figure 4).
- It is also strongly recommended to put a backup thermostat to sufficient fan and heating system parallel to the ECS-5C module output (see figures 5 and 6).
- The backup system and alarm must be thoroughly tested and verified as working properly before using the ventilation system.

Mounting

- The enclosure must be mounted in a location that will allow the cover to be completely opened right up against the wall.
- Fasten the four brackets to the four mounting holes on the back of the enclosure, using the four screws provided with the brackets.
- Then mount the enclosure on the wall by inserting screws through the brackets' adjustment slots, into the wall. Make sure to position the enclosure so that all wires extend out of the bottom section of the enclosure.
- The bracket slots also serve to adjust the position of the controller.
- Once you have adjusted the controller position, tighten the four mounting screws.

FIGURE NO. 1 Mounting Position and Devices

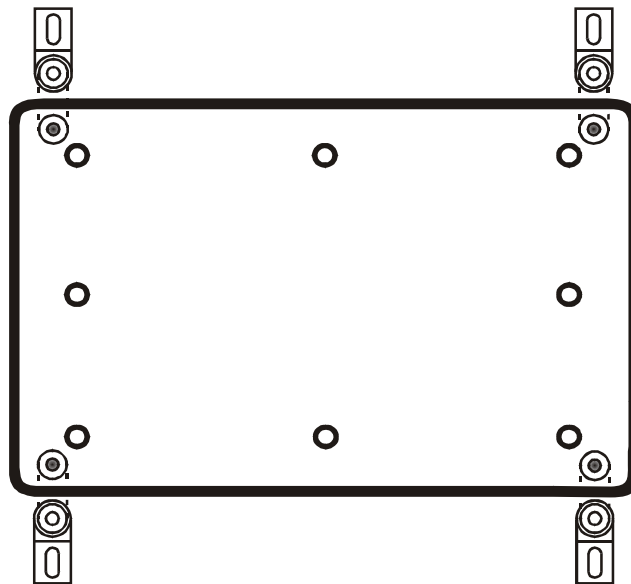

Connection Procedure

Detailed Wiring Diagrams

Typical Sensor Wiring for Probes

The inside temperature sensor should be located in the area which gives the most accurate temperature reading to achieve optimum ventilation. The sensor should also be connected to the ECS-5C with a shielded two-wire cable. It should be located in an area protected from operating machinery, animal bites, personnel or anything that could damage the sensor. See also “General installation guidelines”.

The outside temperature sensor should be installed in a location which is not influenced by heat generated from inside the building or direct sunlight. It should also be protected from physical damage.

FIGURE NO. 2 Typical Temperature Probe Wiring

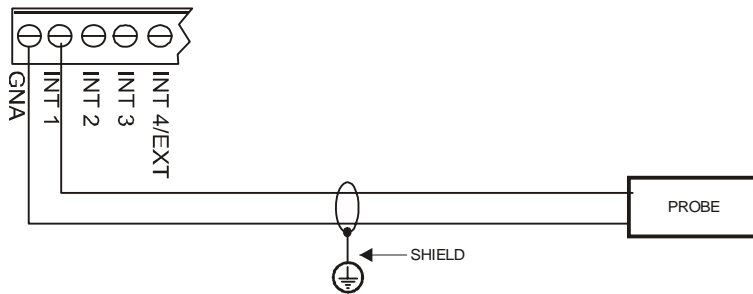
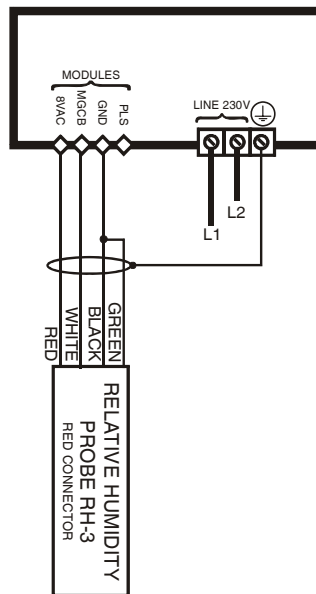

FIGURE NO. 3 Typical Relative Humidity Probe Wiring



Typical Power Backup Wiring

A backup relay (DPDT) connects to the power source 1 in normal operation but will switch to the power source 2 if source 1 is disabled. The backup relay should be selected to ensure it is able to support the required power load.

FIGURE NO. 4 Typical Power Backup Wiring

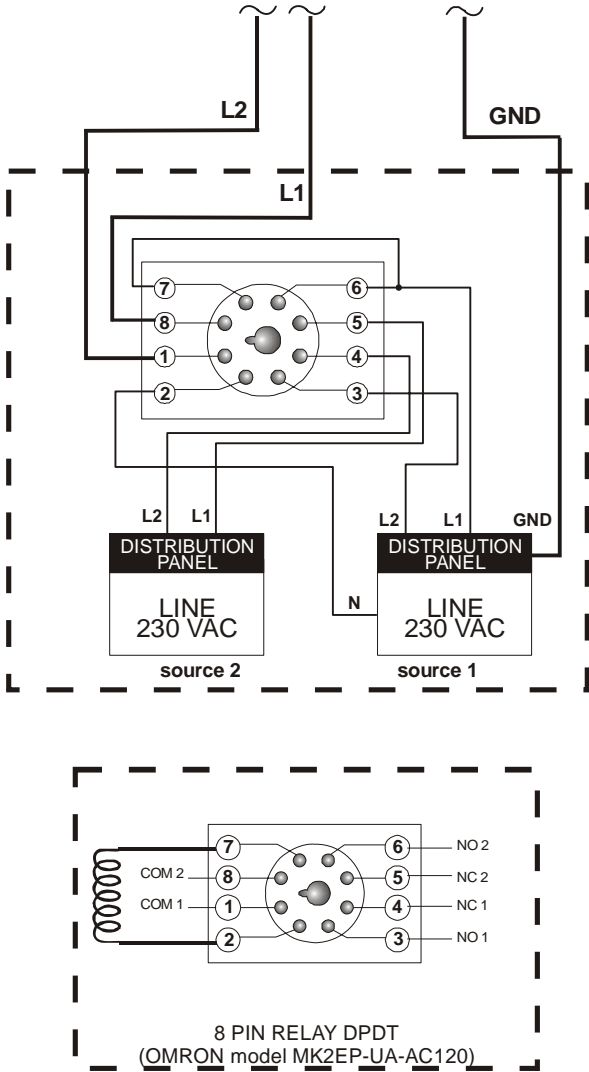

SECTION B

ECS-5C INSTALLATION

Typical Thermostat Backup Wiring

If the ECS-5C fails, the backup thermostats will activate the dedicated fan or heater as soon as temperature reaches the set point of the thermostat. The thermostat must be accessible for adjustment and must be set at 3 to 5 degrees above the fan's relative set point or 3 to 5 degrees under the heater relative set point.

FIGURE NO. 5 Typical Thermostat Backup Wiring on relay

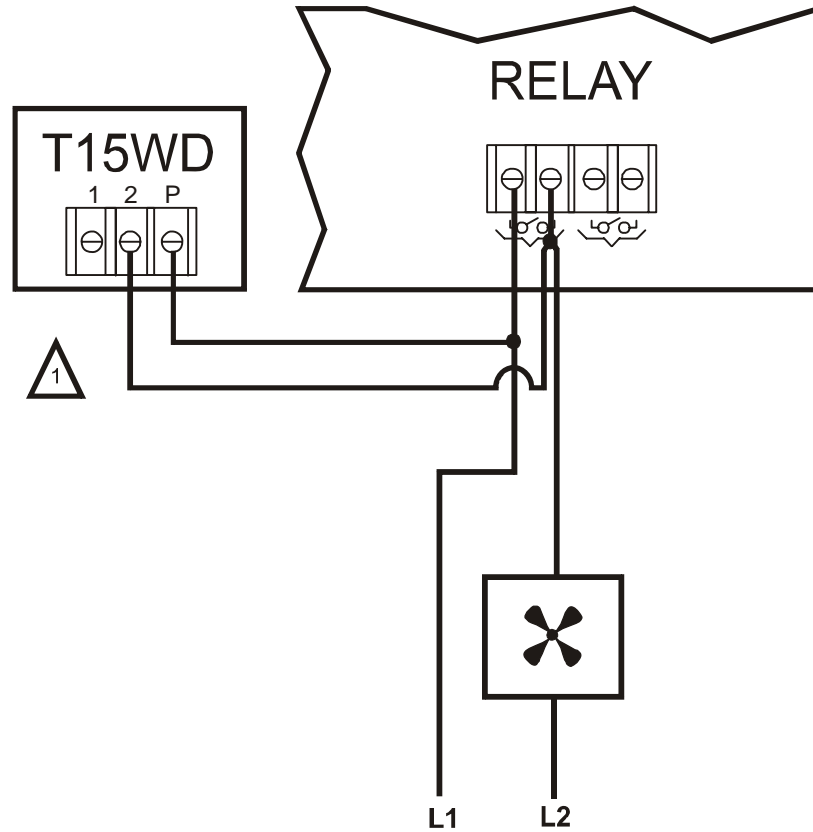

 Optional T15WD safety override connection for relay

FIGURE NO. 6 Typical Thermostat Backup Wiring on variable stage

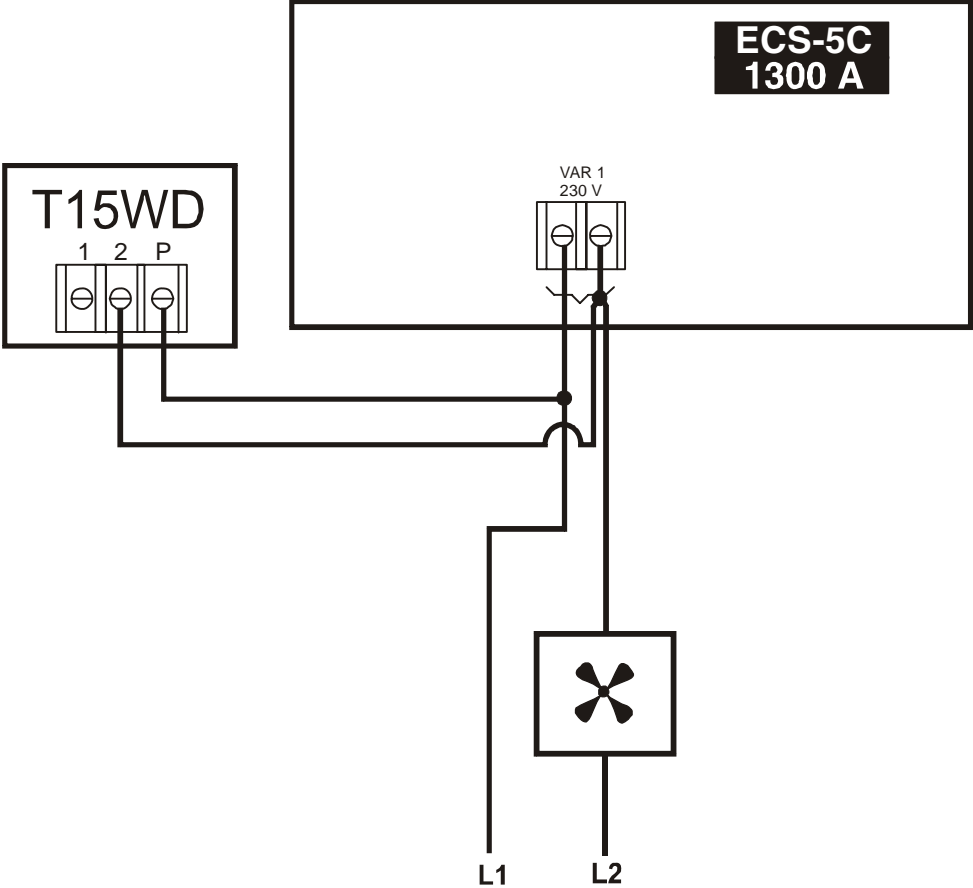

SECTION B

ECS-5C INSTALLATION

Typical Alarm Connection Wiring

The ECS-5C provides a normally closed dry contact to set off an alarm in case of a low or high temperature condition occurs. Moreover, this same contact can be used to signal a power failure or other malfunctions. It may be connected to an alarm system or directly to a siren and /or auto-dialer.

The relay will activate 6-8 seconds after an alarm is triggered.

FIGURE NO. 7 Typical Alarm Connection Wiring

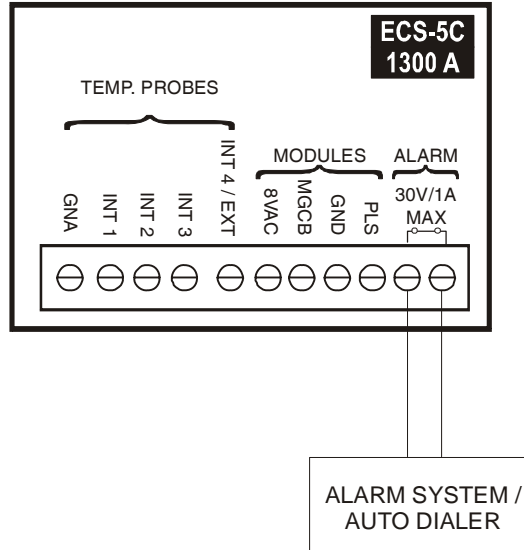

Powering Up Procedure

Once the ECS-5C is properly mounted on the wall and all modules and sensors connected to the terminal block, perform the following step:

Verify all Connections

Seal all cable entry holes.

Hermetically Close the ECS-5C

Close the front panel.

Put the power on

Secure the front panel with a lock

Downloading the Configuration

When upgrading your system with a new configuration, you will have to download the configuration.

There are two ways to download a configuration in the ECS-5C controller.

1) Downloading by powering down.

- A. Ensure the power source of the ECS-5C is OFF (flip the circuit breaker on the distribution panel).
- B. Remove the faceplate screws and lift up the cover.
- C. Insert the configuration chip (MMX) into the socket of the main board.
- D. Switch on the power source. The display on the front panel should indicate `dnLd` for approximately 15 seconds. If `dnLd` is not displayed, try one more time. If `dnLd` is still not displayed, remove and replace the configuration chip (MMX).
- E. When the downloading procedure is complete, remove the configuration chip (MMX) and place it in the bottom part of the enclosure or in another safe location. Once the MMX Chip is removed, the ECS-5C starts up and executes the configuration.

2) Downloading while the ECS-5C is powered up.

- A. Remove the faceplate screws and lift up the cover.
- B. Place the MMX chip into the socket of the main board. At this moment, the **MMX Detected** parameter will appear.
- C. Adjust the **MMX Detected** parameter to `dnLd` and press the `SET/CLR` button. The display on the front panel should indicate `dnLd` for approximately 15 seconds. If `dnLd` is not displayed, try one more time. If `dnLd` is still not displayed, remove and replace the configuration chip (MMX).
- D. When the downloading procedure is complete, remove the configuration chip (MMX) and place it in the bottom part of the enclosure or in another safe location. Once the MMX Chip is removed, the ECS-5C starts up and executes the configuration.

Note: During this procedure, some components are live and can be dangerous if touched.

Uploading the Configuration

It is possible to upload a configuration into a configuration chip (MMX) in order to save parameters and setup or to backup the configuration.

Here's the procedure to upload a configuration.

- A. Make sure that the ECS-5C is powered up.
- B. Remove the faceplate screws and lift up the cover.
- C. Place the MMX chip into the socket of the main board. At this moment, the **MMX Detected** parameter will appear.
- D. Adjust the **MMX Detected** parameter to `UPLd` and press the `SET/CLR` button. The display on the front panel should indicate `UPLd` for approximately 15 seconds. If `UPLd` is not displayed, try one more time. If `UPLd` is still not displayed, remove and replace the configuration chip (MMX).
- E. When the uploading procedure is complete, remove the configuration chip (MMX) and place it in the bottom part of the enclosure or in another safe location. Once the MMX Chip is removed, the ECS-5C will continue to execute the configuration.

WARNING: During this procedure, some components are live and can be dangerous if touched.

ECS-5C Compatible Probes

This is the list of all compatible probes that can be connected with ECS-5C control with a short description of their function.

- **Temperature probe 2004-10K (black cap)**

Temperature probe with a temperature range of -58 to 140°F (-50 to 60°C).

- **Relative humidity probe RH-3**

Relative humidity probe with a measuring range of 0 to 100 RH%. (red connector)

ECS-5C Compatible Modules

This is the list of all compatible modules that can be connected with ECS-5C control with a short description of their function.

Variable speed module

- **VPM-1** (1 variable stage)
- **VPM-2** (2 variable stages)
- **VSM-2** (2 variable stages, with manual toggle switches)

Computer interface

- **NET-IN2 Communication Module** (Module inserted into the controller to communicate with the computer interface)
- **RF-IN Communication Module** (Module inserted into the controller for a wireless communication with the computer interface)

Specifications

Storage temperature	-4°F to 131°F (-20°C to 55°C)
Operating temperature	32°F to 113°F (0°C to 45°C)
Humidity	90% maximum Non-condensing
Weight	3,4 lb (1,6 kg)
Size	9" x 7" x 4 3/4" (22.8 cm x 17.7 cm x 11.5 cm)
Protection index	IP 66
Warranty	2 years
POWER SUPPLY (LINE 230V)	
Operational voltage range	184 to 250VAC
Operational frequency range	45 to 65 Hz
Power supply circuit consumption (CPU Board)	12 VA
SOURCE 8VAC	
Voltage Range	6.5 to 13VAC
Maximum current allowed	50mA
PROBE INPUTS	
Temperature probe	2004-10K
Maximum wire length	500 feet (150 m)
Recommended wires	2 conductors, stranded, shielded, AWG #22
ALARM RELAY	
Maximum current	1 A at 30VDC
Delay before activation	Between 6 and 8 seconds
OUTPUT RELAYS	
Maximum Current	1HP @ 240VAC, 1/2HP @ 120VAC, 10A@240VAC
Caution Notice	These relays are rated by UL and CSA at 1HP @ 240VAC, 1/2HP @ 120VAC. However, for outputs requiring frequent activation (ex: minimum ventilation fans working on a timer) it is recommended not to use more than 1/2HP @ 240VAC, 1/4HP @ 120VAC per relay.
VARIABLE OUTPUTS	
Maximum Allowable Current (Fuse value)	10A, 250VAC
Recommended maximum current for fans	8A, 230VAC
Minimum load	300mA @ 230VAC
PLS OUTPUTS	
Recommended wires	2 conductors, twisted pair (8 twist /ft), AWG #22
Maximum wire length (350pF/m cable)	164ft (50m)
Maximum wire length (89pF/m cable)	656ft (200m)
COMMUNICATIONS PORT (MGCB)	
Maximum wire length (2400 bps)	820 feet (250 m)
Maximum wire length (19200 bps)	6.5 feet (2 m)
Recommended wire	2 strands, twisted pair, low capacity, shielded, AWG #22

ECS-5C INSTALLATION

Important Notice:

- It is important to have a backup system in case of a system failure.
- Low-voltage and high-voltage wire must be passed through different conduits at least 1 foot (30 cm) apart. If low-voltage and high-voltage conduits must be crossed, the crossing must be at a 90-degree angle.
- All wiring must be made by a certified electrician and conform to local electrical regulations.

Troubleshooting

SYMPTOM	CAUSE	REMEDY
Temperature probe reads <i>LO</i>	Temperature is below -58°F (-50°C). Probe is disconnected or defective.	Check all connections. If the problem persists, and the temperature is within normal range, replace the probe.
Temperature probe reads <i>HI</i>	Temperature is above 140°F (60°C). Probe is short circuited or defective.	Check all connections. If the problem persists, and the temperature is within normal range, replace the probe.
Displays are blank	ECS-5C is not powered. Flat cable between the main and top boards of the ECS-5C is disconnected.	Make sure the control is powered. Make sure the fuse is correct. Make sure the flat cable is connected.

USER'S GUIDE

ECS-5C

SECTION C

Control Description

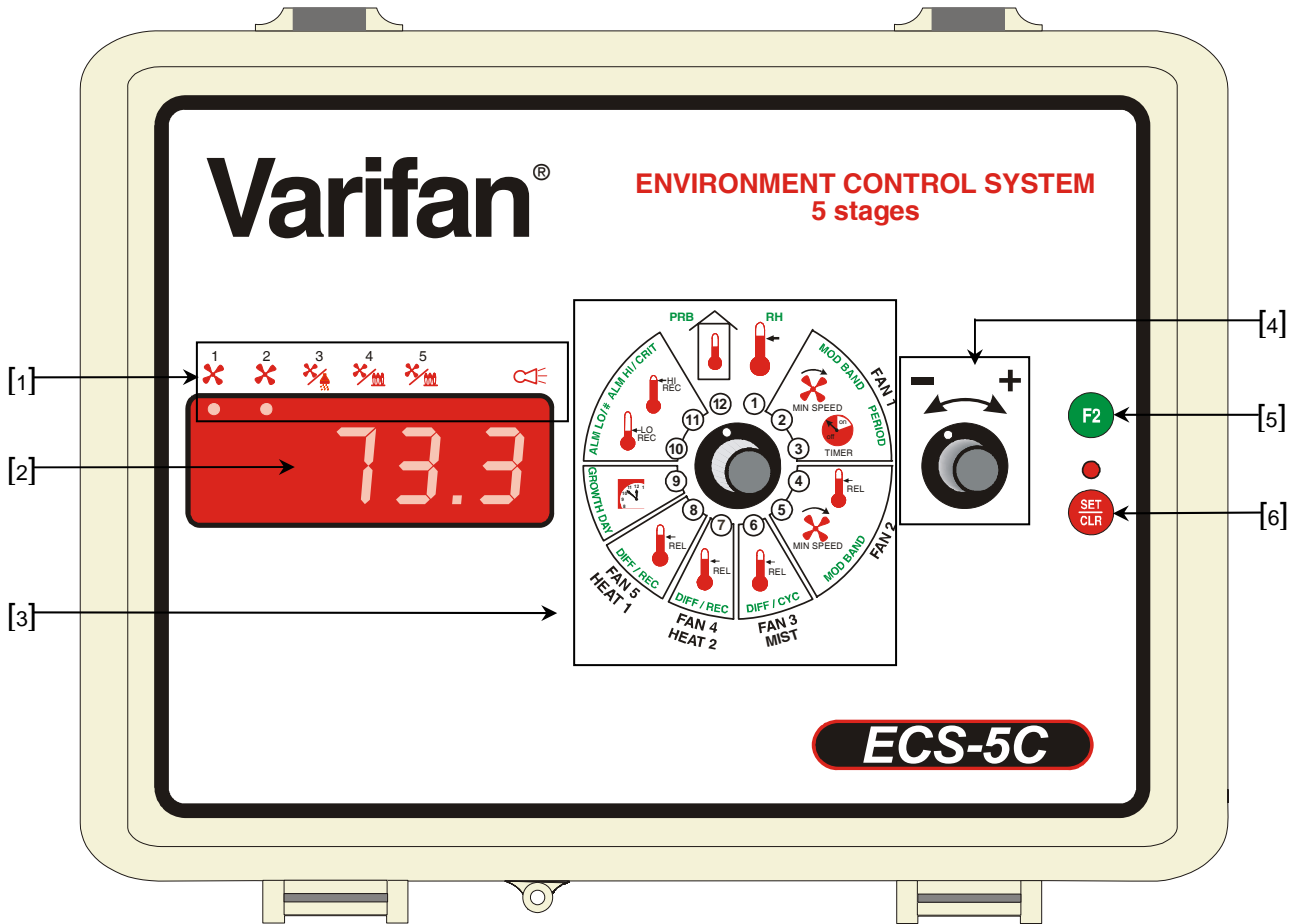

SECTION C

1. Output LED

Those LED indicate the status of an output. A LED comes ON whenever the respective output is active.

2. LED Status Windows

The LED status window features a 5 digit LED readout display of temperature in Fahrenheit or Celsius, or other programmable settings. After a setting is selected, its value appears on the LED display. If the value is flashing, it can be changed with the value setting buttons (◻ and ⊕).

3. Parameter Dial

This button is used to select parameters or parameter groups.

4. Value Setting Button

This button is used to increase or decrease the value on the LED window. Turn it clockwise to increase the value. Turn it counter clockwise to decrease the value.

5. F2 Button

This button is used to access to secondary function of a parameter group (appears in green around the parameter dial).

6. SET/CLR Button

This button is used to acknowledge a function, set a value (clock, curves) or to clear values (min/max).

Input/Output Table

Inputs	Qty	Outputs	Qty
Inside Temperature	1 to 4	Variable Speed Fan	2
Outside Temperature	Up to 1	ON/OFF Stage	Up to 3
Relative Humidity	Up to 1	Mist	Up to 1
		Heater	Up to 2
		Alarm	1

Equipment

Item	Description	Qty
ECS-5C	Environment Control System, 2 Variable / 3 On/Off Outputs	1
2004-10k	Temperature Sensor - Black (-58°F to 140°F) (-50°C to 60°C)	Up to 4
RH-3	Humidity Sensor - Red Connector (0RH% to 100RH%)	Up to 1

Configuration Versions

Version	Date	Min. Proc Version.	Modification
V0	11/27/2008	2	New.
V1	03/30/2010	2	Update for official release.

Ventilation system overview

The ECS-5C uses up to 4 inside temperature probes, one outside temperature probe and 1 humidity probe to control 2 variable fan stages and up to 3 on/off stages. Variable stage 1 can operate according to a timer when temperature is under its activation set point. It may also activate or increase its speed to reduce the humidity level if the latter is high. The first on/off stage can be used as a mist stage or as a fan stage. That stage will operate according to its timer when its activation temperature is reached. The last two on/off stages can operate as heaters or fan stages. Heaters can operate according to the sensors selected by the user.

When a temperature probe is defective (short-circuited or unplugged), the ECS-5C controller will not consider that probe in the average temperature and the alarm will sound. An alarm check will be made to check for high/low temperature and defective probes. The outside temperature may increase the high alarm threshold. The alarm will also activate if the difference between any two inside probes is too great.

Normal Mode Settings



Set Points (POS 1)

Main Set Point

This is the temperature goal for the room, the activation temperature for variable stage 1 and the reference temperature for all relative settings. A fixed differential of 0.3°F (0.2°C) is used with variable stage 1 activation temperature. The **Main Set Point** will follow its growth curve when the **Growth Day** is not FF and the **MSP Curve** option is set to n. The growth curve is composed of four day-points and four temperature-points. To adjust these points, press the SET/CLR button. Then select the point to adjust using the F2 button and adjust it with the adjustment knob. See the **Additional information on parameters** section for more information on the growth curve. The **Main Set Point** is adjusted in 0.1° increments from -40.0°F to 100.0°F (-40.0°C to 37.8°C).

Humidity Set Point rH

This parameter is used to set the humidity level at which variable stage 1 dehumidification will begin. When the **Humidity Probe** reading reaches this set point, variable stage 1 will be activated continuously at **Minimum Speed Variable 1**. If the **Humidity Probe** reading continues to increase, the minimum speed used by variable stage 1 will modulate from **Minimum Speed Variable 1** to reach **Minimum Speed Humidity Variable 1** when **Humidity Probe** reading reaches **Humidity Set Point** + 10RH%. A fixed differential of 3RH% is used with this set point. This parameter is adjusted in 1RH% increments from 0RH% to 100RH%.



Variable Fan 1 (POS 2)

Minimum Speed Variable 1

This parameter is used to establish the minimum speed of variable stage 1. Variable stage 1 will be activated at this speed when **Average Temperature** is equal to the **Main Set Point**, when variable stage 1 is activated by its timer and when **Humidity Probe** is exactly at **Humidity Set Point**. The **Minimum Speed Variable 1** will follow its growth curve when the **Growth Day** is not FF and the **Minimum Speed Variable 1 Curve** option is set to n. The growth curve is composed of four day-points and four speed-points. To adjust these points, press the SET/CLR button. Then select the point to adjust using the F2 button and adjust it with the adjustment knob. See the **Additional information on parameters** section for more information on the growth curve. This parameter is adjusted in 1% increments from 12% to 100%.

Variable 1 Bandwidth

This parameter is used to establish the range of temperature within which variable stage 1 speeds up as the **Average Temperature** increases. Variable stage 1 increases its speed from the **Minimum Speed Variable 1**, when **Average Temperature** is equal to **Main Set Point**, to reach its maximum speed (100%) when **Average Temperature** reaches **Main Set Point + Variable 1 Bandwidth**. This parameter is adjusted in 0.1° increments from 0.5°F to 20.0°F (0.3°C to 11.1°C).



Variable Fan 1 (POS 3)

Minimum Ventilation Variable 1 Cycle Time

This parameter is used to establish the duration of the run time for the variable stage 1 minimum ventilation timer. When the **Average Temperature** is below **Main Set Point**, variable stage 1 will be activated for a percentage (**Minimum Ventilation Variable 1 Cycle Time**) of the **Minimum Ventilation Variable 1 Period**. This parameter is adjusted in 1% increments from 0% to 100%.

Minimum Ventilation Variable 1 Period

This parameter is used to establish the duration of the period for the variable stage 1 minimum ventilation timer. When the **Average Temperature** is below **Main Set Point**, variable stage 1 will be activated for a percentage (**Minimum Ventilation Variable 1 Cycle Time**) of this period. This parameter is adjusted in 1-minute increments from 1 to 10 minutes.



Variable Fan 2 (POS 4)

Relative Temperature Variable 2

This parameter is used to establish the relative temperature at which variable stage 2 will activate. When the **Average Temperature** reaches **Main Set Point + Relative Temperature Variable 2**, variable stage 2 will activate at **Minimum Speed Variable 2**. A fixed differential of 0.3°F (0.2°C) is used with this RSP. This parameter is adjusted in 0.1° increments from 0.5°F to 20.0°F (0.3°C to 11.1°C).



Variable Fan 2 (POS 5)

Minimum Speed Variable 2

This parameter is used to establish the minimum speed of variable stage 2. Variable stage 2 will be activated at this speed when **Average Temperature** is equal to the **Main Set Point + Relative Temperature Variable 2**. This parameter is adjusted in 1% increments from 12% to 100%.

Variable 2 Bandwidth

This parameter is used to establish the range of temperature within which variable stage 2 speeds up as the **Average Temperature** increases. Variable stage 2 increases its speed from the **Minimum Speed Variable 2**, when **Average Temperature** is equal to **Main Set Point + Relative Temperature Variable 2**, to reach its maximum speed (100%) when **Average Temperature** reaches **Main Set Point + Relative Temperature Variable 2 + Variable 2 Bandwidth**. This parameter is adjusted in 0.1° increments from 0.5°F to 20.0°F (0.3°C to 11.1°C).

**Fan 3 / Mist (POS 6)****Relative Temperature Fan 3 / Mist**

This parameter is used to establish the relative temperature at which fan 3 will activate. When the **Average Temperature** reaches **Main Set Point + Relative Temperature Fan 3 / Mist**, fan 3 will activate according to its timer. This parameter is adjusted in 0.1° increments from 0.5°F to 20.0°F (0.3°C to 11.1°C).

Differential Fan 3 / Mist

This parameter is used to set the differential for fan 3. Fan 3 will deactivate when **Average Temperature** is equal to or below **Main Set Point + Relative Temperature Fan 3 / Mist - Differential Fan 3 / Mist**. This parameter is adjusted in 0.1° increments from 0.5°F to 20.0°F (0.3°C to 11.1°C).

Fan 3 / Mist Cycle Time

This parameter is used to establish the duration of the run time for the mist timer. When the **Average Temperature** is equal to or above **Main Set Point + Relative Temperature Fan 3 / Mist**, fan 3 / mist will be activated for a percentage (**Fan 3 / Mist Cycle Time**) of the **Fan 3 / Mist Period**. This parameter is adjusted in 1-minute increments from 1 to 10 minutes.

**Fan 4 / Heater 2 (POS 7)****Relative Temperature Fan 4 / Heater 2**

This parameter is used to establish the relative temperature at which fan 4 / heater 2 will activate. If **Logic Out 4** is set to , fan 4 will activate when the **Average Temperature** is equal to or above **Main Set Point + Relative Temperature Fan 4 / Heater 2**. If **Logic Out 4** is set to , heater 2 will activate when the average temperature of the probes selected in **Heater 2 Probe {1-4}** is equal to or below **Main Set Point + Relative Temperature Fan 4 / Heater 2**. This parameter is adjusted in 0.1° increments from -20.0°F to 20.0°F (-11.1°C to 11.1°C).

Differential Fan 4 / Heater 2

This parameter is used to establish the relative temperature at which fan 4 / heater 2 will deactivate. If **Logic Out 4** is set to , fan 4 will deactivate when the **Average Temperature** is equal to or below **Main Set Point + Relative Temperature Fan 4 / Heater 2 - Differential Fan 4 / Heater 2**. If **Logic Out 4** is set to , heater 2 will deactivate when the average temperature of the probes selected in **Heater 2 Probe {1-4}** is equal to or above **Main Set Point + Relative Temperature Fan 4 / Heater 2 + Differential Fan 4 / Heater 2**. This parameter is adjusted in 0.1° increments from 0.5°F to 20.0°F (0.3°C to 11.1°C).

Heater 2 Record

This parameter displays the time for which heater 2 has been activated since the ECS-5C was powered up or since this parameter was last cleared. To reset this value to 0, press the button. The **Heater 2 Record** is displayed to the nearest minute from 0 to 32760 minutes.



Fan 5 / Heater 1 (POS 8)

Relative Temperature Fan 5 / Heater 1

This parameter is used to establish the relative temperature at which fan 5 / heater 1 will activate. If **Logic Out 5** is set to , fan 5 will activate when the **Average Temperature** is equal to or above **Main Set Point + Relative Temperature Fan 5 / Heater 1**. If **Logic Out 5** is set to , heater 1 will activate when the average temperature of the probes selected in **Heater 1 Probe {1-4}** is equal to or below **Main Set Point + Relative Temperature Fan 5 / Heater 1**. This parameter is adjusted in 0.1° increments from -20.0°F to 20.0°F (-11.1°C to 11.1°C).

Differential Fan 5 / Heater 1

This parameter is used to establish the relative temperature at which fan 5 / heater 1 will deactivate. If **Logic Out 5** is set to , fan 5 will deactivate when the **Average Temperature** is equal to or below **Main Set Point + Relative Temperature Fan 5 / Heater 1 - Differential Fan 5 / Heater 1**. If **Logic Out 5** is set to , heater 1 will deactivate when the average temperature of the probes selected in **Heater 1 Probe {1-4}** is equal to or above **Main Set Point + Relative Temperature Fan 5 / Heater 1 + Differential Fan 5 / Heater 1**. This parameter is adjusted in 0.1° increments from 0.5°F to 20.0°F (0.3°C to 11.1°C).

Heater 1 Record

This parameter displays the time for which heater 1 has been activated since the ECS-5C was powered up or since this parameter was last cleared. To reset this value to 0, press the button. The **Heater 1 Record** is displayed to the nearest minute from 0 to 32760 minutes.



Clock / Growth Day (POS 9)

Clock

This parameter gives the time of day in the format chosen in **Clock Format**. To adjust the time of day, press the **SET/CLR** button. At this moment, the minutes will be adjustable. Press the **F2** button to toggle between hour and minute adjustments. Press the **SET/CLR** button once again or change parameters with the parameter selection knob once the adjustments are finished.

Growth Day **9 day**

This parameter is used to adjust the growth day of the ECS-5C controller. If this day is not set to **DEF**, it will determine the value of the **Main Set Point** (if **MSP Curve** is set to **0n**) and the **Minimum Speed Variable 1** (if **Minimum Speed Variable 1 Curve** is set to **0n**) according to the day and value points of the growth curve. The **Growth Day** is adjusted in 1-day increments from **DEF**, day -10 to day 365.



Low Temperature Record And Alarm (POS 10)

Low Average Temperature Record

This parameter displays the lowest value reached by the **Average Temperature** since the ECS-5C was powered up or since this parameter was last cleared. To reset this value to the actual **Average Temperature**, press the **SET/CLR** button. The **Low Average Temperature Record** is displayed to the nearest 0.1° from -58.0°F to 140.0°F (-50.0°C to 60.0°C).

Relative Temperature Low Alarm **RL LD**

This parameter is used to establish the relative temperature at which a low temperature alarm condition will occur. When **Average Temperature** is below the **Main Set Point + Relative Temperature Low Alarm**, a low temperature alarm condition will occur. This parameter is adjusted in 0.1° increments from -40.0°F to -0.5°F (-22.2°C to -0.3°C).

Alarm Code ALCODE

This setting displays the alarm condition. This parameter displays 0 when no errors have been detected. This indicates that the controller has operated properly since it was powered up or since the **Alarm Code** was last cleared. The last alarm condition will be displayed until the **Alarm Code** is cleared. To clear the **Alarm Code**, press the SET/CLR button, CLR will appear on the LED display. This will reset the **Alarm Code** to 0 if no alarm condition is present. The alarm LED () on the faceplate will be lit up if an alarm situation is actually present. The alarm code refers to the following table.

Alarm Code List:

Alarm Code	Description
1	Average Temperature Too Low
2	Average Temperature Too High
3	Sensor 1 Defective
4	Sensor 2 Defective
5	Sensor 3 Defective
6	Sensor 4 Defective
7	Outside Sensor Defective
8	Sensor 1 Gap Exceeds Limit
9	Sensor 2 Gap Exceeds Limit
10	Sensor 3 Gap Exceeds Limit
11	Sensor 4 Gap Exceeds Limit
12	Heater 1 Has No Probes Assigned
13	Heater 2 Has No Probes Assigned
101	The controller has reset 10 times and each reset was less than 15 minutes apart from the last one.
102	If this alarm code appears, contact your distributor
103	If this alarm code appears, contact your distributor

SECTION C

	<h3>High Temperature Record And Alarm (POS 11)</h3>
---	---

High Average Temperature Record

This parameter displays the highest value reached by the **Average Temperature** since the ECS-5C was powered up or since this parameter was last cleared. To reset this value to the actual **Average Temperature**, press the SET/CLR button. The **High Average Temperature Record** is displayed to the nearest 0.1° from -58.0°F to 140.0°F (-50.0°C to 60.0°C).

Relative Temperature High Alarm

This parameter is used to establish the relative temperature at which a high temperature alarm condition will occur. When **Average Temperature** is above the **Main Set Point + Relative Temperature High Alarm**, a high temperature alarm condition will occur. This limit may be affected by the **Outside Probe** if that probe is used and the **Relative Outside Temperature Alarm** is set to a value other than . This parameter is adjusted in 0.1° increments from 0.5°F to 40.0°F (0.3°C to 22.2°C).

Critical High Alarm

This parameter is used to establish the temperature set point at which a high temperature alarm condition will occur regardless of the **Outside Probe** reading. When the **Average Temperature** is above this parameter, a high temperature alarm condition will occur. Setting this parameter to will deactivate the critical high alarm check. This parameter is adjusted in 0.1° increments from -40.0°F to 119.9°F (-40.0°C to 48.8°C), .

**Probes (POS 12)****Average Temperature**

This parameter displays the actual average temperature of all activated inside probes. The average is made from the inside temperature probes whose DIP SWITCH is set to the ON position (see DIP Switches and Slide Switches Table page 43). The **Average Temperature** is displayed to the nearest 0.1° from -58.0°F to 140.0°F (-50.0°C to 60.0°C).

Probe 1

This parameter displays the actual probe 1 temperature. The **Probe 1** temperature is displayed to the nearest 0.1° from -58.0°F to 140.0°F (-50.0°C to 60.0°C).

Probe 2

This parameter displays the actual probe 2 temperature. This parameter will appear only if DIPSW2 is set to the ON position (see DIP Switches and Slide Switches Table page 43). The **Probe 2** temperature is displayed to the nearest 0.1° from -58.0°F to 140.0°F (-50.0°C to 60.0°C).

Probe 3

This parameter displays the actual probe 3 temperature. This parameter will appear only if DIPSW3 is set to the ON position (see DIP Switches and Slide Switches Table page 43). The **Probe 3** temperature is displayed to the nearest 0.1° from -58.0°F to 140.0°F (-50.0°C to 60.0°C).

Probe 4

This parameter displays the actual probe 4 temperature. This parameter will appear only if DIPSW4 is set to the ON position and DIPSW5 is set to the OFF position (see DIP Switches and Slide Switches Table page 43). The **Probe 4** temperature is displayed to the nearest 0.1° from -58.0°F to 140.0°F (-50.0°C to 60.0°C).

Outside Probe

This parameter displays the actual outside probe temperature. This parameter will appear only if DIPSW5 is set to the ON position (see DIP Switches and Slide Switches Table page 43). This reading may increase the high temperature alarm threshold. The **Outside Probe** temperature is displayed to the nearest 0.1° from -58.0°F to 140.0°F (-50.0°C to 60.0°C).

Humidity Probe

This parameter displays the actual humidity probe readout. This parameter will appear only if DIPSW6 is set to the ON position (see DIP Switches and Slide Switches Table page 43). This parameter may display if the humidity probe is defective or unplugged. Otherwise, the **Humidity Probe** reading is displayed to the nearest 1RH% from 0RH% to 100RH%.

System Mode Settings

(POS 1)

MSP Curve

This parameter is used to activate or deactivate the growth curve function of the **Main Set Point**. If this parameter is set to and the **Growth Day** is not , the **Main Set Point** will follow its day and value points and will no longer be adjustable. See the Additional information on parameters section for more information on the growth curve. If this parameter is set to , the **Main Set Point** will not be affected by its growth curve.

Minimum Speed Variable 1 Curve

This parameter is used to activate or deactivate the growth curve function of the **Minimum Speed Variable 1**. If this parameter is set to and the **Growth Day** is not , the **Minimum Speed Variable 1** will follow its day and value points and will no longer be adjustable. See the Additional information on parameters section for more information on the growth curve. If this parameter is set to , the **Minimum Speed Variable 1** will not be affected by its growth curve.

(POS 2)**Motor Curve Variable 1**

This parameter is used to modify the motor curve of the variable stage 1. The relation between the voltage supplied to a motor and its operation speed is defined by the motor curve. This curve may vary according to the brand and the capacity of the motor. The motors available in the industry have been regrouped in eight categories and a different curve has been programmed in the controller for each category. The appropriate curve must be chosen for each motor to ensure a correct relation between the voltage supplied and the desired speed. Refer to the **Motor Curve** table in the attachment section (p.44) for the list of different motor curves and their associated fans. These parameters may be set to any value from 1 to 9.

Motor Curve Variable 2

This parameter is used to modify the motor curve of the variable stage 1. The relation between the voltage supplied to a motor and its operation speed is defined by the motor curve. This curve may vary according to the brand and the capacity of the motor. The motors available in the industry have been regrouped in eight categories and a different curve has been programmed in the controller for each category. The appropriate curve must be chosen for each motor to ensure a correct relation between the voltage supplied and the desired speed. Refer to the **Motor Curve** table in the attachment section (p.44) for the list of different motor curves and their associated fans. These parameters may be set to any value from 1 to 9.

(POS 3)**Logic Out 5**

This parameter is used to select the mode in which output 5 will operate. If this parameter is set to , output 5 will activate when the **Average Temperature** is high. If this parameter is set to , output 5 will activate when the average temperature of the probes selected in **Heater 1 Probe {1-4}** is low.

Logic Out 4

This parameter is used to select the mode in which output 4 will operate. If this parameter is set to , output 4 will activate when the **Average Temperature** is high. If this parameter is set to , output 4 will activate when the average temperature of the probes selected in **Heater 2 Probe {1-4}** is low.

(POS 4)

Heater 1 Probe 1 P1:HE1

This parameter is used to assign **Probe 1** to the temperature heater 1 will follow. If this parameter is set to On, **Probe 1** will be averaged with the other selected probes to compose the temperature heater 1 will follow. If this parameter is set to OFF, **Probe 1** will not be included in the temperature heater 1 will follow. This parameter will appear only if **Logic Out 5** is set to HEAT.

Heater 1 Probe 2 P2:HE1

This parameter is used to assign **Probe 2** to the temperature heater 1 will follow. If this parameter is set to On, **Probe 2** will be averaged with the other selected probes to compose the temperature heater 1 will follow. If this parameter is set to OFF, **Probe 2** will not be included in the temperature heater 1 will follow. This parameter will appear only if **Logic Out 5** is set to HEAT and DIPSW2 is set to the ON position (see DIP Switches and Slide Switches Table page 43).

Heater 1 Probe 3 P3:HE1

This parameter is used to assign **Probe 3** to the temperature heater 1 will follow. If this parameter is set to On, **Probe 3** will be averaged with the other selected probes to compose the temperature heater 1 will follow. If this parameter is set to OFF, **Probe 3** will not be included in the temperature heater 1 will follow. This parameter will appear only if **Logic Out 5** is set to HEAT and DIPSW3 is set to the ON position (see DIP Switches and Slide Switches Table page 43).

Heater 1 Probe 4 P4:HE1

This parameter is used to assign **Probe 4** to the temperature heater 1 will follow. If this parameter is set to On, **Probe 4** will be averaged with the other selected probes to compose the temperature heater 1 will follow. If this parameter is set to OFF, **Probe 4** will not be included in the temperature heater 1 will follow. This parameter will appear only if **Logic Out 5** is set to HEAT, DIPSW4 is set to the ON position and DIPSW5 is set to the OFF position (see DIP Switches and Slide Switches Table page 43).

(POS 5)

Heater 2 Probe 1 P1:HE2

This parameter is used to assign **Probe 1** to the temperature heater 2 will follow. If this parameter is set to On, **Probe 1** will be averaged with the other selected probes to compose the temperature heater 2 will follow. If this parameter is set to OFF, **Probe 1** will not be included in the temperature heater 2 will follow. This parameter will appear only if **Logic Out 4** is set to HEAT.

Heater 2 Probe 2 P2:HE2

This parameter is used to assign **Probe 2** to the temperature heater 2 will follow. If this parameter is set to On, **Probe 2** will be averaged with the other selected probes to compose the temperature heater 2 will follow. If this parameter is set to OFF, **Probe 2** will not be included in the temperature heater 2 will follow. This parameter will appear only if **Logic Out 4** is set to HEAT and DIPSW2 is set to the ON position (see DIP Switches and Slide Switches Table page 43).

Heater 2 Probe 3 P3:HE2

This parameter is used to assign **Probe 3** to the temperature heater 2 will follow. If this parameter is set to On, **Probe 3** will be averaged with the other selected probes to compose the temperature heater 2 will follow. If this parameter is set to OFF, **Probe 3** will not be included in the temperature heater 2 will follow. This parameter will appear only if **Logic Out 4** is set to HEAT and DIPSW3 is set to the ON position (see DIP Switches and Slide Switches Table page 43).

Heater 2 Probe 4 P4:HE2

This parameter is used to assign **Probe 4** to the temperature heater 2 will follow. If this parameter is set to On, **Probe 4** will be averaged with the other selected probes to compose the temperature heater 2 will follow. If this parameter is set to OFF, **Probe 4** will not be included in the temperature heater 2 will follow. This parameter will appear only if **Logic Out 4** is set to HEAT, DIPSW4 is set to the ON position and DIPSW5 is set to the OFF position (see DIP Switches and Slide Switches Table page 43).

(POS 6)**Fan 3 / Mist Period** PER3

This parameter is used to establish the duration of the period for the mist timer. When the **Average Temperature** is equal to or above **Main Set Point + Relative Temperature Fan 3 / Mist**, fan 3 / mist will be activated for a percentage (**Fan 3 / Mist Cycle Time**) of this period. This parameter is adjusted in 1% increments from 0% to 100%.

Minimum Speed Humidity Variable 1 SPdHr

This parameter is used to set the speed variable stage 1 will take for full dehumidification. When **Humidity Probe** is equal to or above **Humidity Set Point**, the minimum speed used by variable stage 1 will modulate from **Minimum Speed Variable 1**, at **Humidity Set Point**, to reach **Minimum Speed Humidity Variable 1** when **Humidity Probe** reading reaches **Humidity Set Point + 10RH%**. This parameter is adjusted in 1% increments from 12% to 100%.

(POS 8)

Gap Between Probes Alarm

This parameter is used to establish the maximum temperature difference tolerated between an activated inside temperature probe and the temperature calculation that the probe is part of. If the temperature difference between two probes is greater than this parameter, the alarm will sound. The probe with the biggest gap will be eliminated and then another check will be made to verify if another probe exceeds the maximum temperature gap allowed and eliminated it. When two or fewer probes remain in the temperature calculation, **Gap Between Probes Alarm** will no longer be checked. All probes eliminated this way will be excluded from all temperature calculations. This parameter is adjusted in 0.1° increments from 0.5°F to 20.0°F (0.3°C to 11.1°C).

Relative Outside Temperature Alarm

This parameter is used to establish the temperature that will be added to the **Outside Probe** to create the high alarm threshold. When the **Outside Probe** is above the **Main Set Point**, the high alarm condition will occur if the **Average Temperature** is above **Outside Probe + Relative Outside Temperature Alarm**. Setting this parameter to will deactivate the outside temperature's influence on the high alarm threshold. This parameter is adjusted in 0.1° increments from 0.5°F to 40.0°F, (0.3°C to 22.2°C,).

(POS 9)

Clock Format

This parameter is used to set the format in which the time of day will be displayed. Is this parameter is set to , the **Clock** parameter will be displayed in the 24-hour format. Is this parameter is set to , the **Clock** parameter will be displayed in the AM/PM format.

Language

This parameter is used to select the language used by the ECS-5C. Is this parameter is set to , the configuration will use the English language. Is this parameter is set to , the configuration will use the French language.

(POS 10)

PC ID

This parameter is used to select the identification number that will be used when communicating with the remote access software. Each controller must have a unique PC identification number. This parameter may be adjusted to any value from 1 to 250.

(POS 11)**Configuration Version**

This parameter displays the version of the configuration actually used.

Processor Version

This parameter displays the version of the processor actually used.

(POS 12)**System Parameters**









This parameter indicates that the ECS-5C is in system parameter mode.

Communication Filter





This parameter is reserved for the manufacturer's technical support personnel.

Parameter Table

Note : Some parameters will not be visible depending on certain settings. See Normal Mode Settings and System Mode Settings sections for more details

Normal Mode Settings (Accessible when SW2 is set to OFF)			
	Parameters	Default	Range
(POS 12) PROBES 	Average Temperature	—	-58.0 to 140.0°F (-50.0 to 60.0°C)
	[F2] – P:1 – Probe 1	—	
	[F2] – P:2 – Probe 2	—	
	[F2] – P:3 – Probe 3	—	
	[F2] – P:4 – Probe 4	—	
	[F2] – P:OUT – Outside Probe	—	
	[F2] – P:rH – Humidity Probe	—	0 to 100RH%
(POS 1) SET POINTS 	Main Set Point (MSP) (4-point curve)	67.0°F (19.4°C)	-40.0 to 100.0°F (-40.0 to 37.8°C)
	[F2] – rH – Humidity Set Point	65RH%	0 to 100RH%
(POS 2) VARIABLE FAN 1  MIN SPEED	Minimum Speed Variable 1 (4-point curve)	40%	12 to 100%
	[F2] – band – Modulation Band Variable 1	2.0°F (1.1°C)	0.5 to 20.0°F (0.3 to 11.1°C)
(POS 3) VARIABLE FAN 1  TIMER	Minimum Ventilation Variable 1 Cycle Time	30%	0 to 100%
	[F2] – PER – Minimum Ventilation Variable 1 Period	5 min	1 to 10 min
(POS 4) VARIABLE FAN 2  REL	Relative Temperature Variable 2	2.0°F (1.1°C)	0.5 to 20.0°F (0.3 to 11.1°C)
(POS 5) VARIABLE FAN 2  MIN SPEED	Minimum Speed Variable 2	40%	12 to 100%
	[F2] – band – Modulation Band Variable 2	2.0°F (1.1°C)	0.5 to 20.0°F (0.3 to 11.1°C)
(POS 6) FAN 3  REL	Relative Temperature Fan 3 / Mist	3.0°F (1.7°C)	0.5 to 20.0°F (0.3 to 11.1°C)
	[F2] – dIFF – Differential Fan 3 / Mist	2.0°F (1.1°C)	0.5 to 20.0°F (0.3 to 11.1°C)
	[F2] – CYC – Fan 3 / Mist Cycle	25%	0 to 100%
(POS 7) FAN 4/HEATER 2  REL	Relative Temperature Fan 4 / Heater 2	4.0°F (2.2°C)	-20.0 to 20.0°F (-11.1 to 11.1°C)
	[F2] – dIFF – Differential Fan 4 / Heater 2	2.0°F (1.1°C)	0.5 to 20.0°F (0.3 to 11.1°C)
	[F2] – rEC – Heater 2 Record	—	0 to 32760 min

SECTION C

<p>(POS 8) FAN 5/HEATER 1</p> 	Relative Temperature Fan 5 / Heater 1	5.0°F (2.8°C)	-20.0 to 20.0°F (-11.1 to 11.1°C)
	[F2] - dIFF - Differential Fan 5 / Heater 1	2.0°F (1.1°C)	0.5 to 20.0°F (0.3 to 11.1°C)
	[F2] - rEL - Heater 1 Record	—	0 to 32760 min
<p>(POS 9) CLOCK / GROWTH DAY</p> 	Clock	—	—
	[F2] - GdRY - Growth Day	OFF	OFF, -10 to 365
<p>(POS 10) LOW TEMPERATURE RECORD and ALARM</p> 	Low Average Temperature Record	—	-58.0 to 140.0°F (-50.0 to 60.0°C)
	[F2] - RL LD - Relative Temperature Low Alarm	-10.0°F (-5.6°C)	-40.0 to -0.5°F (-22.2 to -0.3°C)
	[F2] - REdE - Alarm Code	—	—
<p>(POS 11) HIGH TEMPERATURE RECORD and ALARM</p> 	High Average Temperature Record	—	-58.0 to 140.0°F (-50.0 to 60.0°C)
	[F2] - RL HI - Relative Temperature High Alarm	12.0°F (6.7°C)	0.5 to 40.0°F (0.3 to 22.2°C)
	[F2] - CrI t - Critical High Alarm	100.0°F (37.8°C)	-40.0 to 119.9°F, OFF (-40.0 to 48.8°C, OFF)

System Mode Settings (Accessible when SW2 is set to ON)

	Parameters	Default	Range
(POS 1)	[SELP] – MSP Curve	ON	ON/OFF
	[F2] – [SPd1] – Minimum Speed Variable 1 Curve	ON	
(POS 2)	[1CUR] – Motor Curve Variable 1	7	1 to 9
	[F2] – [2CUR] – Motor Curve Variable 2	7	
(POS 3)	[OUT 5] – Logic Out 5	COOL	HEAT / COOL
	[F2] – [OUT 4] – Logic Out 4	COOL	
(POS 4)	[P1:HE1] – Probe 1 Heater 1	ON	ON/OFF
	[F2] – [P2:HE1] – Probe 2 Heater 1	ON	
	[F2] – [P3:HE1] – Probe 3 Heater 1	ON	
	[F2] – [P4:HE1] – Probe 4 Heater 1	ON	
(POS 5)	[P1:HE2] – Probe 1 Heater 2	ON	ON/OFF
	[F2] – [P2:HE2] – Probe 2 Heater 2	ON	
	[F2] – [P3:HE2] – Probe 3 Heater 2	ON	
	[F2] – [P4:HE2] – Probe 4 Heater 2	ON	
(POS 6)	[PER3] – Fan 3 / Mist Period	5min	1 to 10 min
	[F2] – [SPdHr] – Minimum Speed Humidity Variable 1	50%	12 to 100%
(POS 7)	—	—	—
(POS 8)	[GAP P] – Gap Between Probes Alarm	3.0°F (1.7°C)	0.5 to 20.0°F (0.3 to 11.1°C)
	[F2] – [OUTAL] – Relative Outside Temperature Alarm	12.0°F (6.7°C)	0.5 to 40.0°F, OFF (0.3 to 22.2°C, OFF)
(POS 9)	[Hr Fr] – Clock Format	24hr	AM-PM, 24hr
	[F2] – [LANG] – Display Language	Eng	Eng, Fra
(POS 10)	[PC ID] – PC ID	1	1 to 250
(POS 11)	[CONF] – Configuration Version	—	—
	[F2] – [PRDL] – Processor Version	—	—
(POS 12)	[SYSTEM] – System Parameters	—	—
	[F2] – [FILTER] – Communication Filter	300 sec	0 to 300 sec

DIP Switches and Slide Switches Table

	Switches	Default	Settings
SLIDE SWITCHES	(SW1) – Parameters Lock	OFF (Unlock)	ON = Lock / OFF = Unlock
	(SW2) – System Mode Parameters	OFF (Normal)	ON = System / OFF = Normal
DIP SWITCHES	(DIPSW1) – Temperature Unit	OFF (°F)	ON = °C / OFF = °F
	(DIPSW2) – Probe 2	OFF	ON/OFF
	(DIPSW3) – Probe 3	OFF	ON/OFF
	(DIPSW4) – Probe 4	OFF	ON/OFF
	(DIPSW5) – Probe 4 Inside/Out.	OFF (Inside)	ON = Outside / OFF = Inside
	(DIPSW6) – Humidity Probe	OFF	ON/OFF
	(DIPSW7) – Future Use	—	—
	(DIPSW8) – Future Use	—	—

Motor Curve

TYPE OF MOTOR				
CURVE	BRAND	MODEL	VOLTAGE	HEIGHT
1	Multifan	4E40	230 V.	16"
2	Flex	FM0025	230 V.	18"
2	Multifan	2E20	230 V.	8"
2	Multifan	4E35	230 V.	14"
2	Multifan	4E50	230 V.	20"
2	Multifan	AF24M'E	230 V.	24"
2	Multifan	6E63	230 V.	24"
2	Multifan	6E71	230 V.	28"
2	Multifan	8E92	230 V.	36"
2	Ziehl		230 V.	
3	Flex	FM0024	230 V.	14"
3	Flex	FM0024	230 V.	16"
3	Flex	FM0026	230 V.	24"
3	Multifan	2E30	230 V.	12"
3	Multifan	4E45	230 V.	18"
3	Multifan	6E56	230 V.	22"
3	Multifan/AF	AF36M	230 V.	36"
3	Aerotech-F	AT242	230 V.	24"
4	Multifan	2E25	230 V.	10"
4	Marathon 1/4HP		230 V.	16"
4	Marathon 1/3HP		230 V.	18"
5	GE Motor	5KCP39...	230 V.	12"
5	Leeson 1/4HP	AF12L	230 V.	12"
5	GE Motor	5KCP39...	230 V.	14"
5	Emerson	K55HXJ...	230 V.	14"
6	Oversized motors			
7	Flex	FM0024	230 V.	12"
7	Flex	FM0026	230 V.	20"
7	Multifan	4E30	230 V.	12"
7	Multifan	2E35	230 V.	14"
8	Multifan	4E25	230 V.	10"

Additional information on parameters

The following is a more detailed description of general-purpose parameters.

Time of Day (time clock)

The ECS-5C comes with its own integrated time clock. This feature is appreciated by users who want to know the current time of day. Note that if a power failure occurs, the clock will not run and will start back at the time the power failure occurred. However, the time clock's main purpose is to allow ramping to operate.

The following instructions show how to change the time of day on the control:

The time is displayed in HH:MM format and does not flash. Press the **SET/CLR** button to access clock adjustment mode. At this moment, the minutes will flash and be adjustable. Press the **F2** button to toggle between hour and minute adjustments. Press the **SET/CLR** button or change the parameter selection knob position to exit the clock adjustment mode.

Growth Day

The Growth Day plays an active part in the ramping settings. With this parameter, users can program the growth day of a growth curve. Day by day, the growth calendar's value will increase by increment of 1, from a minimum setting of -10 to a maximum of 365.

Ramping

The ramping parameter automatically will calculate and change its value every hour. The amount by which the parameter is changed is determined by the ramping curve.

Before the first point, the parameter takes the value entered for the first point. For example, point 1 is at 80°F at day #10. From day #1 to day #10, the value will be 80°F.

After the last point, the curve remains operational. While it continues to count days, the set point does not flash and cannot be changed. For example, the last point (day #40) is set at 70°F. After day #40 the parameter remains at 70°F, until ramping is deactivated, by setting the Growth Day to OFF.

The following instructions indicate how to set the Growth Day of a ramping curve:

Select the ramping parameter (ex: Main Set Point, Minimum speed, etc.). Make sure the Growth day is set to OFF. Press the **SET/CLR** button. At this moment, the first day of the growth curve will be displayed.

When a day is displayed, pressing the **F2** button will display the associated value. When a value is displayed, pressing the **F2** button will display the next day.

The following graph shows a typical ramping curve for the temperature.

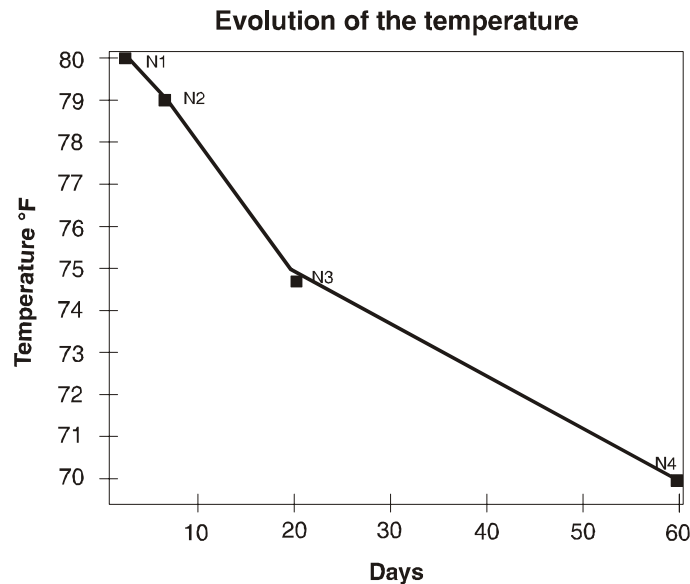

This four points curve may be entered as follows:

1. Make sure the Growth Day is OFF.
2. Select the Ramping parameter with the parameter selection knob and the **F2** button.
3. The value on the LED display should be flashing.
4. Press the **SET/CLR** button. At this moment, the LED display will show **0 1: DAY** (the first day point of the curve).
5. Set this value to 1 using the adjustment knob.
6. Press the **F2** button. The LED display will show **0 1: Pt** (the first value point of the curve).
7. You may now enter the first temperature value for curve (80°F) using the adjustment knob.
8. Press the **F2** button. At this moment, the next day will be displayed and adjustable.
9. Repeat steps 5 to 8 for the rest of the curve points. In this example, the days are 8, 20 and 60 and the value points are 79°F, 75°F and 70°F.
10. Once the last value point is entered, press the **SET/CLR** button. You should now be back to a point where the LED display is flashing a temperature value.

11. The whole ramping curve is now set. To enable temperature ramping, simply set the Growth Day to any day value and the ECS-5C will follow the curve.

Ramping is interrupted when days fail to respect a chronological order or when to consecutive points have the same day. This characteristic may be useful to users unwilling to use all 4 “preset” ramping points. The following illustration shows how users can stop the curve without entering the last point.

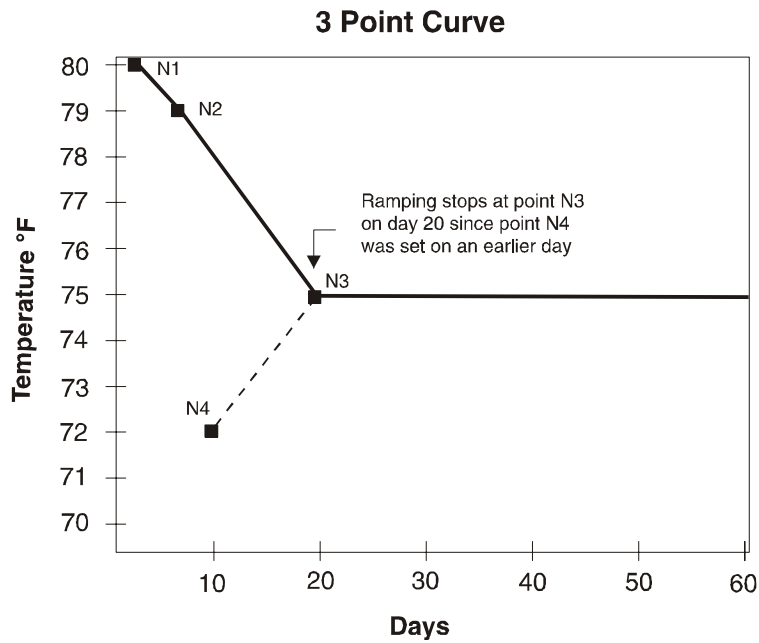

**INDEX /
WARRANTY
ECS-5C
SECTION D**

TABLE OF CONTENTS

	Section A
WARNINGS AND PRECAUTIONS.....	2
Wiring Diagram	4
Electrician’s notes	5

TABLE OF CONTENTS

	Section B
Unpacking.....	7
Mounting Hardware Required	7
General installation guidelines	8
ECS-5C Control.....	8
Electrical Cables.....	8
Electrical Power.....	9
Mounting.....	9
Connection Procedure	10
Detailed Wiring Diagrams.....	10
Typical Sensor Wiring for Probes.....	10
Typical Power Backup Wiring.....	11
Typical Thermostat Backup Wiring	12
Typical Alarm Connection Wiring	14
Powering Up Procedure.....	15
Verify all Connections.....	15
Hermetically Close the ECS-5C	15
Put the power on	15
Secure the front panel with a lock	15
Downloading the Configuration.....	16
Uploading the Configuration	17
ECS-5C Compatible Probes	18
ECS-5C Compatible Modules	18
Specifications.....	19
Troubleshooting	21

TABLE OF FIGURES

FIGURE NO. 1 Mounting Position and Devices.....	9
FIGURE NO. 2 Typical Temperature Probe Wiring.....	10
FIGURE NO. 3 Typical Relative Humidity Probe Wiring	10
FIGURE NO. 4 Typical Power Backup Wiring	11
FIGURE NO. 5 Typical Thermostat Backup Wiring on relay.....	12
FIGURE NO. 6 Typical Thermostat Backup Wiring on variable stage	13
FIGURE NO. 7 Typical Alarm Connection Wiring	14

TABLE OF CONTENTS

	Section C
Control Description	23
Input/Output Table.....	25
Equipment	25
Configuration Versions	25
Ventilation system overview	26
Normal Mode Settings	27
Set Points (POS 1)	27
Variable Fan 1 (POS 2)	27
Variable Fan 1 (POS 3)	28
Variable Fan 2 (POS 4)	28
Variable Fan 2 (POS 5)	28
Fan 3 / Mist (POS 6).....	29
Fan 4 / Heater 2 (POS 7).....	29
Fan 5 / Heater 1 (POS 8).....	30
Clock / Growth Day (POS 9).....	31
Low Temperature Record And Alarm (POS 10)	31
High Temperature Record And Alarm (POS 11)	32
Probes (POS 12)	33
System Mode Settings	34
(POS 1).....	34
(POS 2).....	35
(POS 3).....	35
(POS 4).....	36
(POS 5).....	36
(POS 6).....	37
(POS 8).....	38
(POS 9).....	38
(POS 10).....	38
(POS 11).....	39
(POS 12).....	39
Parameter Table	40
Normal Mode Settings (Accessible when SW2 is set to OFF)	40
System Mode Settings (Accessible when SW2 is set to ON).....	42
DIP Switches and Slide Switches Table	43
Motor Curve	44
Additional information on parameters	45
Time of Day (time clock).....	45
Growth Day.....	45
Ramping	45

TABLE OF CONTENTS

	Section D
Limited Warranty.....	51

SECTION D

Limited Warranty

The manufactured equipment and supplied components have gone through rigorous inspection to assure optimal quality of product and reliability. Individual controls are factory tested under load, however the possibility of equipment failure and/or malfunction may still exist.

For service, contact your local retailer or supplier. The warranty period shall be for two years from manufacturing date. Proof of purchase is required for warranty validation.

In all cases, the warranty shall apply only to defects in workmanship and specifically exclude any damage caused by over-voltage, short circuit, misuse, acts of vandalism, lightning, fortuitous events, acts of God, flood, fire, hail or any other natural disaster. Any unauthorized work, modification or repair on this product automatically voids the warranty and disclaims the manufacturer from all responsibility.

The manufacturer assumes only those obligations set forth herein, excluding all other warranties or obligations. This warranty stipulates that in all cases the manufacturer shall be liable only for the supply of replacement parts or goods and shall not be liable for any personal injury, damages, loss of profits, interrupted operations, fines for infringement of the law or damages to the production of the PURCHASER and the PURCHASER shall take up the defense and hold the manufacturer faultless regarding any legal or extra legal proceedings, notice, or claim by the customer or by a third party, and regarding any legal and extra legal expenses and fees brought forward on by such damages.

