

# ECS-1M

## USER'S MANUAL

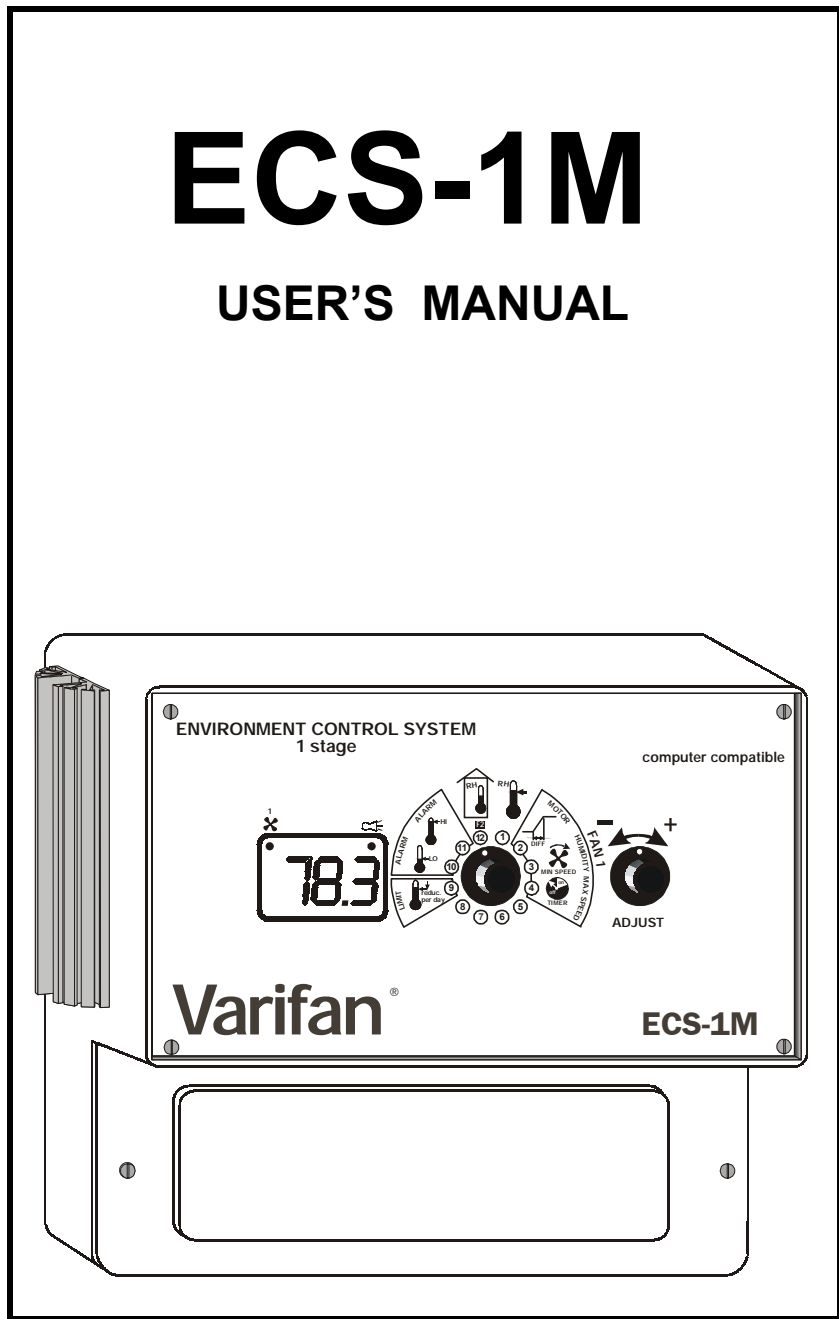

Although the manufacturer has made every effort to ensure the accuracy of the information contained herein, this document is subject to change without notice due to ongoing product development.

### **WARNING AND PRECAUTIONS**

Equipment, probe failure, blown fuses and/or tripped breakers may prove harmful to the contents of the building. Therefore it is strongly recommended to install backup devices and alarm or warning devices. Spare equipment should also be available at the owner's site. Equipment manufactured by the manufacturer is protected against normal line surges. High surges caused by thunder storms or power supply equipment may damage this equipment. For added security against line voltage surges, it is recommended that surge and noise suppression devices be installed at the electrical distribution panel. Use of shielded cable for probes is recommended for protection against lightning. These devices are available from most electrical supply distributors.

### **RECOMMENDATIONS**

The manufacturer recommends that all installation procedures described herein be performed by a qualified electrician or installation technician. Furthermore the manufacturer recommends to test all the functions and equipment connected to the ECS, including the alarm system and backup devices, after installation, after modifications, and once a month after that.

Fuse verification and replacement, as well as the proper setting of control values, shall be the responsibility of the owner of this equipment.

*TABLE OF CONTENTS*

---

---

**CHAPTER 1 - INTRODUCTION**

1.	General .....	5
1.1	Description .....	5
	Definition of terms .....	7

**CHAPTER 2 - INSTALLATION**

2.1	Unpacking .....	9
2.2	Mounting .....	10
2.3	Switch Settings.....	10
2.3.1	Line Voltage Selector Switch .....	10
2.3.2	Software Settings Switch .....	11
2.4	Connection Procedure .....	11
2.4.1	Input Power .....	11
2.4.1.1	115 VAC.....	11
2.4.1.2	230 VAC.....	12
2.4.2	Fan 1 .....	12
2.5	Temperature/Humidity Probes .....	12
2.5.1	Single Temperature Probe .....	13
2.5.2	Averaging .....	13
2.5.3	Humidity Probe.....	13
2.6	Alarm.....	13
2.7	Powering Up.....	14

**CHAPTER 3 - USER GUIDE**

LED Status Window .....	21
Control Dials.....	21

**PRIMARY FUNCTIONS**

Main Set Point Temperature .....	23
Fan 1 Differential.....	24
Fan 1 Minimum Speed.....	25
Fan 1 Duty Cycle.....	26

**CONTENTS CONTINUED...**

Ramping ..... 27  
Record Low Temperature 2 ..... 8  
Record High Temperature ..... 29  
Ambient Room Temperature Display ..... 30

**SECONDARY FUNCTIONS**

Relative Humidity Set Point ..... 31  
Fan 1 Motor ..... 32  
Fan 1 Minimum Humidity Speed ..... 33  
Fan 1 Maximum speed ..... 34  
Minimum Ramping ..... 35  
Low Temperature Alarm ..... 36  
High Temperature Alarm ..... 37  
Relative Humidity Display ..... 38

**APPENDIX**

Motor Compatibility Table ..... 39  
Troubleshooting ..... 40  
Specification ..... 41  
Record Form ..... 42

## **1. GENERAL**

This document provides a description of the ECS 1M control panel. This document is organized as follows:

- Introduction
- Installation
- User's Guide
- Appendix

### **1.1 DESCRIPTION**

Congratulations on the purchase of your ECS 1M environmental control system. The ECS M product line provides you with full control over temperature, humidity, air flow, and heat resulting in a comfortable environment for your livestock.

The ECS M product line offers a number of added features over existing ECS controls such as:

- Compatible with EPM-10 and DIP-1.
- Hi/Lo temperature indication.
- Automatic temperature reduction (ramping).
- Adaptable variable speed outputs for a wide selection of fan model types.
- Humidity probe.
- Full torque fan start preventing motor damage.

The ECS 1M provides microprocessor control over a single stage output.

This stage controls a variable speed fan which can operate at a continuous low speed to ensure good quality of air when the room temperature is below the main set point. In addition, the first stage may be programmed to cycle on and off. When the room temperature rises above the main set point, the fan accelerates to increase the air flow.

## **DESCRIPTION CONTINUED...**

The ECS 1M provides you with full control over one stage via the use of an easy to follow display panel. All programmable features can be customized to meet your requirements. The ECS 1M keeps you constantly informed by displaying the status of all of its outputs as well as the ambient temperature. With an optional humidity probe, the ECS 1M displays current humidity levels.

Safety of livestock is ensured by the continuous control of climate and timely alarm notification should environmental conditions exceed alarm set points. Further security may be obtained by connecting all ECS series controls in a network configuration to a computer via the use of an optional RCM 40 remote monitoring unit. This provides remote control monitoring of each room. The control panel variable output is fused, and all programmable settings are maintained whether or not the ECS 1M is powered.

The ECS 1M provides an automatic constant temperature reduction (ramping) feature for your maturing livestock. A built in low temperature safety factor prevents temperatures reaching dangerous limits.

The ECS 1M can control an EPM-10. This control is designed to position an air inlet baffle board or air inlet curtain without the use of a feedback potentiometer or 0 - 10 volts analog signal. The EPM-10 provides an automated positioning of your air inlet according to the signal sent by the ECS 1M, or alternatively by manual position knob control on the EPM-10 .

With ECS 1M in control of your climate, you are assured of optimal living conditions for your livestock.

*DEFINITION OF TERMS*

---

---

**MAIN SET POINT**

The desired room temperature. Other temperature settings on the ECS 1M are relative to the main set point temperature.

**RELATIVE TEMPERATURE**

A value added to or subtracted from the main set point which results in a new temperature at which a desired action starts or stops.

**AMBIENT TEMPERATURE**

The actual temperature of the room.

**AMBIENT HUMIDITY**

The actual humidity level of the room.

**MINIMUM FAN SPEED**

The desired minimum speed for variable speed fans.

**RAMPING**

An automatic daily reduction in the main set point and all temperature settings relative to this.

*ECS 1M*

---

---

---

---

*Page 8*



## CHAPTER 2 - INSTALLATION

---

---

Chapter 2 describes the installation of the ECS 1M control panel.

**The manufacturer recommends that the installation instructions which follow be adhered to as closely as possible, and all work be performed by a certified electrician. Failure to do so may void the warranty!**

### 2.1 UNPACKING

Unpack the ECS 1M from its box and inspect contents for damage. Should the contents appear to be damaged, contact your local distributor for return material procedures.

The package should contain the following standard items:

- 1 ECS 1M control .
- 1 installed temperature probe (model number 2004-1K).
- 2 cable fasteners or fuses.
- 1 User manual.

The following optional items may be included:

- 3 additional temperature probes for temperature averaging,
- 1 humidity probe. The ECS 1M requires the RHT-1 humidity probe for maximum accuracy of monitoring and control of humidity levels.

## 2.2 MOUNTING

To limit the unit's exposure to noxious gases install the unit in a hallway.

Make certain that the unit is mounted right side up with the cable entry holes facing down.

The ECS 1M will operate in a temperature range of 32°F - 120 °F (0 °C - 50 °C).

\* It is prohibited to use overhead cables outside the building.

Mount the control panel to the wall using the mounting holes located on the flange of the control housing

**Mounting hardware is not shipped with the unit.**

Once the ECS 1M is in place, use a screwdriver to remove the six screws holding the faceplate to the housing.

## 2.3 SWITCH SETTINGS

The ECS 1M is configured for a variety of options via two switches as follows:

### 2.3.1 - Line Voltage Selector Switch

This switch is located on the surface of the main (bottom) board and adapts the control panel for 115 VAC or 230 VAC line voltage.

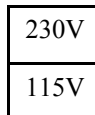

Refer to Figures 1, and 2.

## CHAPTER 2 - INSTALLATION

### 2.3.2 - Software Settings Switch

This switch is located at the rear of the control panel faceplate and adjusts the following options.

	OFF	ON
1	Fahrenheit	Celsius
2	Settings locked	Setting unlocked
3		When used with a DIP-1
4		Relative Humidity

- Switch 1 Selects between a Fahrenheit or Celsius display on the front panel.
- Switch 2 Locks/unlocks user settings. All settings except for main set point, record low, and record high are locked while this switch is off.
- Switch 3 Must be ON when using a DIP-1 control.
- Switch 4 To connect a humidity probe, DIP switch #4 must be ON

## 2.4 CONNECTION PROCEDURE

For the connection procedures which follow refer to Figures 1 and 2.

### 2.4.1 - Input power

Use a screwdriver to remove cable knock-outs for the installation of cabling to the control panel.

#### 2.4.1.1 - 115 VAC

**Make certain that the line voltage selector switch is set to 115 VAC.** Connect the power cable to terminals 5 and 6 on the main (bottom) board, connect the ground wire to the terminal 7 on the main board .

**Do not apply power to the control panel until all connections have been completed!**

**2.4.1.2 - 230 VAC**

**Make certain that the line voltage selector switch is set to 230 VAC.** Connect the power cable to terminals 5 and 6 on the main (bottom) board, connect the ground wire to terminal 7 on the main board.

**2.4.2 - Fan 1 (terminals 5 and 6)**

Connect the two leads from Fan 1 to terminals 5 and 6 on the main (bottom) board.

**2.5 TEMPERATURE / HUMIDITY PROBES**

Temperature and humidity probes use a “Class 2” low voltage circuit. These cables can extend up to a distance of 500 feet (150 meters). Single probe temperature and humidity connections are illustrated in Figure 4 while temperature probe averaging connections are illustrated in Figure 5.

**Use shielded cabling for probes . Connect the shields to “SHLD” terminal. Failure to do so may result in inaccurate readings!**

### **2.5.1 Single Temperature Probe**

Install a single temperature probe in an area that best reflects the overall temperature of the room. Connect the two leads and the shield of the temperature probe to the control panel terminals labelled “Probe” as indicated in Figure 3.

### **2.5.2 Averaging (optional)**

Four temperature probes are required if temperature averaging is desired in larger rooms. Place the probes in appropriate locations to best average the ambient temperature. Refer to Figure 4.

### **2.5.3 Humidity Probe (optional)**

Install one humidity probe in an area that best reflects the overall humidity of the room. Connect the humidity probe to the control panel terminals labeled “Probe” as indicated in Figure 3.

## **2.6 ALARM**

The ECS 1M provides a normally open and normally closed dry contact for alarming low or high temperature conditions. In addition, this same contact can be used to signal a power failure. This contact may be connected to an alarm system, or directly to a siren and/or auto-dialer.

Make normally open or normally closed connections as indicated in Figure 3.

**Momentary power interruptions may trigger false alarms! To avoid false alarming when the ECS 1M is connected to an alarm system, install a time delay relay between the ECS 1M and the alarm system.**

## 2.7 POWERING UP

Before powering up the ECS 1M, attach the faceplate to the casing of the control panel using the six screws previously removed.

Set Selector knob to position (12).

Upon power up, the unit will test it's display by briefly lighting all the segments of it's LED. Make certain that all segments light.

Following the LED display test, the unit displays the ambient temperature of the room.

If the temperature is not displayed, refer to the Trouble Shooting section in the appendix of this document.

Fig. 1  
One Fan (115V)

---

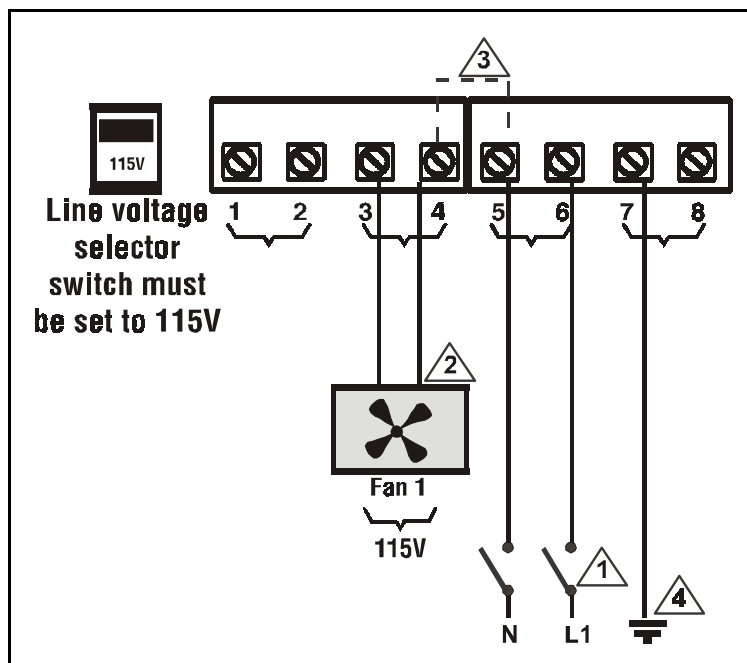
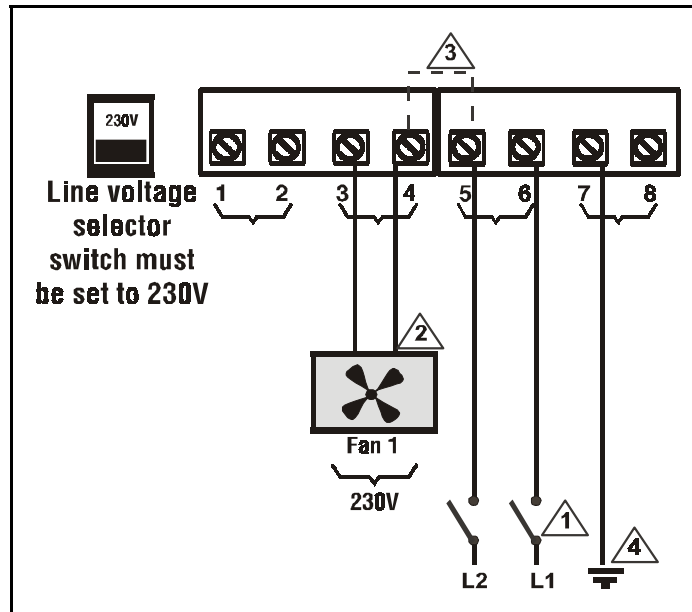

Fig. 2  
One Fan (230V)



**Notes for Figures 1, and 2**

- ⚠ Power cut and protection devices in case of overload.
- ⚠ Only use fans that have thermal protection devices.
- ⚠ Terminals 4 and 5 are internally connected.
- ⚠ Connect the grounding wire to the ground terminal 7 .

Fig. 3.  
Probes and Alarm Wiring

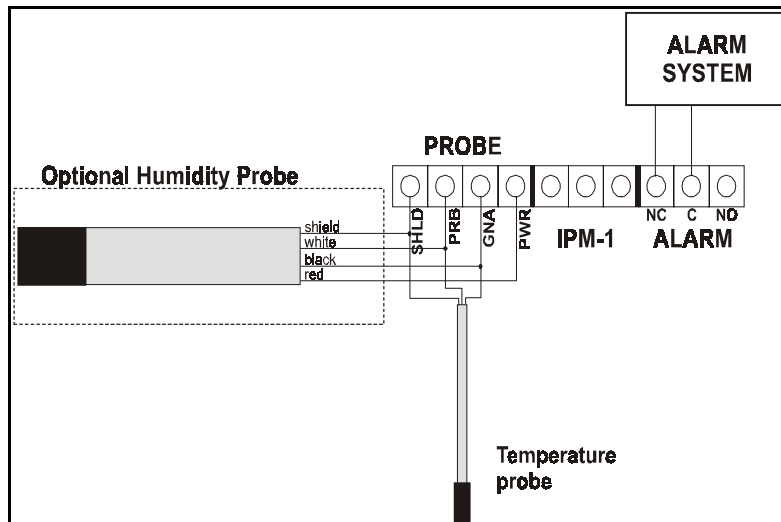
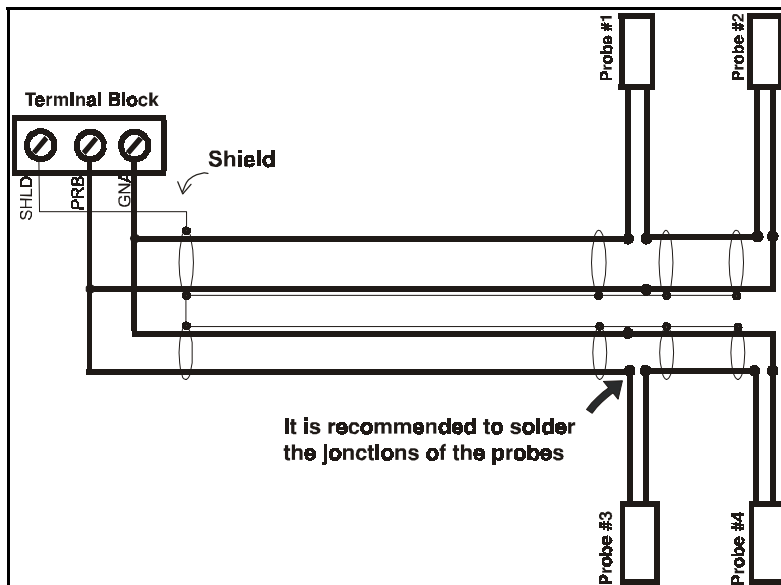

Fig. 4  
Temperature Averaging Probe Connection





**CHAPTER 2 - INSTALLATION**

---

Fig. 5  
Main Board: Terminal, Blocks, Switches, Fuses and Ground

---

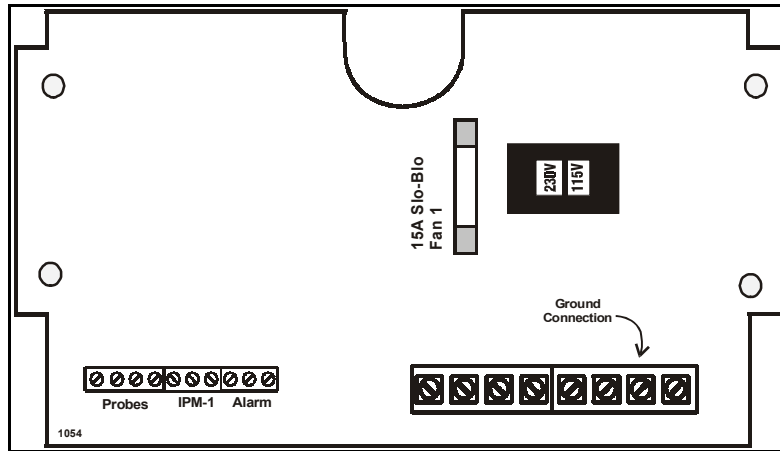

## **VARIFAN RECOMMENDED CONTROL BACKUP**

### **WARNING AND PRECAUTIONS**

Equipment failure, blown fuses and/or tripped breakers may prove harmful to the content of the building. It is therefore strongly recommended to install backup devices and alarm or warning devices (see example fig. 6).

**BACKUP THERMOSTAT.** If the Varifan control fails, then the thermostat will start the dedicated fan at full speed when the temperature will reach the T15-WD set value. Therefore, the T15-WD should be accessible for its adjustment and it should be set at the same temperature as the alarm, i.e. approximately 5°F above the fan relative set point.

**BACKUP POWER SOURCE.** The DPDT relay connects to the source 1 in normal operation but will switch to the source 2 if source 1 is off. The relay shall be chosen to support the load connect to it.

**ALARM CIRCUIT.** In normal operation, the alarm circuit of the Varifan Control is a short circuit. But if the Varifan control is defective or if there is no power applied to it, then the alarm circuit of the control will be an open circuit.

**CHAPTER 2 - INSTALLATION**

Fig 6.  
Recommended control backup

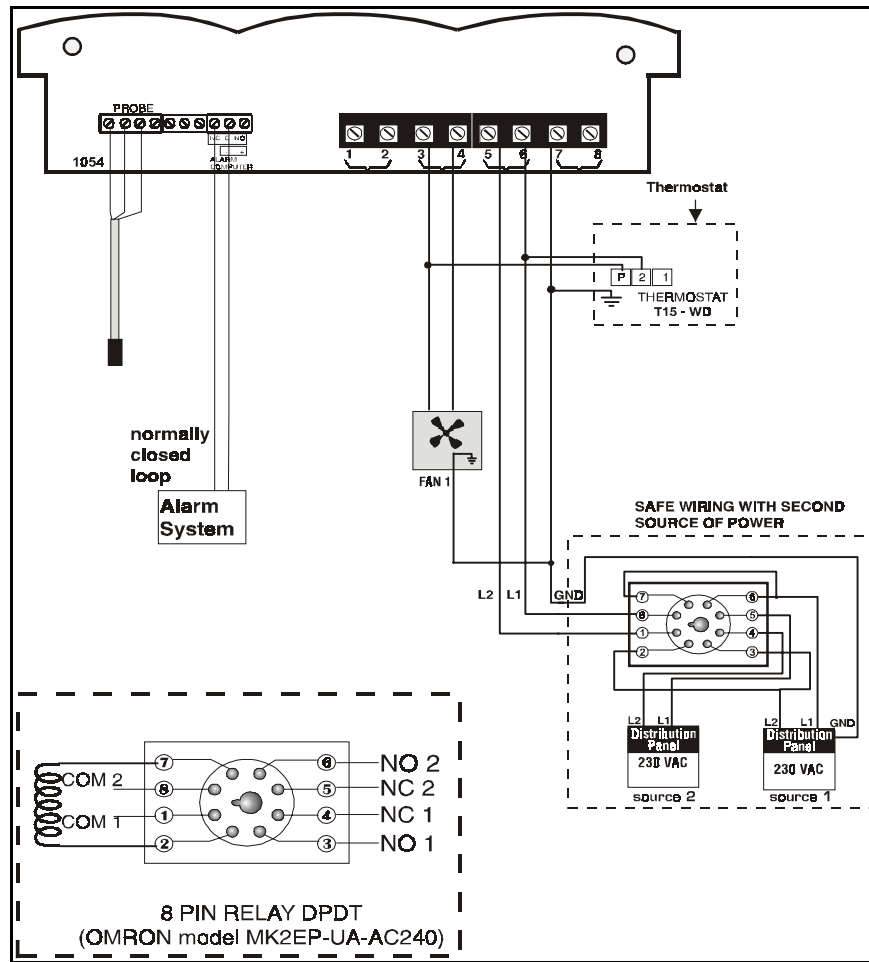



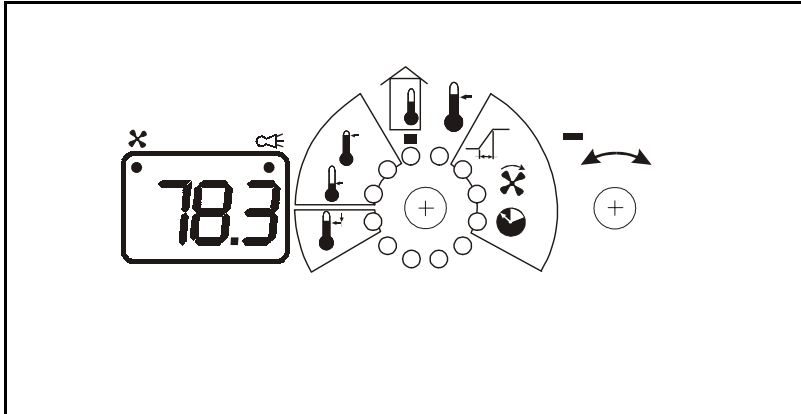

The ECS 1M front panel shown above features a LED status window and two control dials which are respectively used to select a function and adjust a setting.

**LED STATUS WINDOW**

The LED status window features a 3 digit LED readout for the display of temperature in Fahrenheit or Celsius, humidity level, and programmable settings.

In addition, the LED status window displays the operational status of Fans 1 via one LED (shown above in LED window). When illuminated, the LED indicates that the fan is operating. The second LED lights to indicate a low or high temperature alarm condition.

**CONTROL DIALS**

The center dial is the Selector dial and is used to select one of the control panel's 8 primary or 8 secondary functions. The dial located to the right of the Selector dial is the Adjustor dial and is used to enter secondary function mode and to adjust the setting of each function.

## *ECS 1M*

---

The 8 primary functions are:

- 1 Main set point temperature
- 2 Fan 1 differential temperature
- 3 Fan 1 minimum speed
- 4 Fan 1 duty cycle timer
- 9 Ramping
- 10 Record low temperature display
- 11 Record high temperature display
- 12 Ambient temperature display

Any one of these functions is selected by rotating the Selector dial to the corresponding number and associated graphical image printed on the faceplate of the panel. When primary functions 1 through 4 and 9 through 11 are selected, the LED status window displays a blinking value. Function 12 displays ambient temperature.

The 8 secondary functions are:

- 1 Relative humidity setting
- 2 Fan 1 motor compatibility
- 3 Fan 1 minimum speed setting for humidity
- 4 Fan 1 maximum speed
- 9 Ramping minimum temperature limit
- 10 Low temperature alarm
- 11 High temperature alarm
- 12 Relative humidity display

Select any one of these secondary mode functions by: rotating the Selector dial to (12) rapidly rotating the Adjustor dial back and forth to enter secondary mode. rotating the Selector dial from function (12) to any other function.

When secondary functions 1 through 4, and 9 through 11 are selected the status window displays a blinking value along with a scrolling LED display. Selection of function 12 removes the ECS from the secondary function mode.

---

## PRIMARY FUNCTIONS

---

### MAIN SET POINT

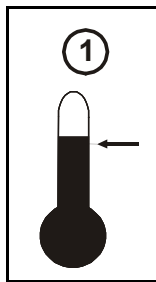

The main set point establishes the target temperature in the building. This value is used as the reference point for other settings. The main set point temperature is adjusted in 0.5 degree increments from a minimum setting of 13.5°F (-9.5°C) to a maximum setting of 105.0° F (41.0°C).

**Adjusting the main set point temperature:**

- rotate the Selector dial to position (1),
- rotate the Adjustor dial counterclockwise to decrease the temperature setting, clockwise to increase it.

The main set point temperature is displayed on the ECS.

**Note: The ramping feature (primary function 9) must be (OFF) to adjust the main set point.**

## FAN 1 DIFFERENTIAL

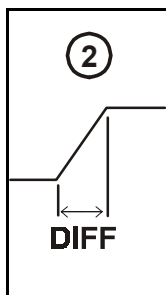

The Fan 1 differential setting establishes the temperature at which Fan 1 reaches maximum speed. The value is a temperature **difference** from the main set point.

The Fan 1 differential is adjusted in 0.5 degree increments from a minimum setting of 2.0°F (1.0°C) to a maximum setting of 18.0°F (10.0°C).

### **Adjusting the Fan 1 differential:**

- rotate the Selector dial to position (2),
- rotate the adjustment dial counterclockwise to decrease the temperature setting, clockwise to increase it.

The Fan 1 Differential setting is displayed on the ECS.

**Example: A main set point temperature of 70°F along with a Fan 1 differential setting of 5°F is set. When the temperature of the room reaches 75°F, Fan 1 operates at its maximum speed.**



## FAN 1 MINIMUM SPEED



This function sets the minimum speed of Fan 1 when room temperature is below the main set point. This value is entered as a percentage of fan maximum speed. The Fan 1 minimum speed is adjusted in 2% increments from a minimum setting of 12% to a maximum setting of 100%.

### Adjusting the minimum speed of Fan 1:

- rotate the Selector dial to position (3),
- rotate the Adjustor dial counterclockwise to decrease fan speed, clockwise to increase it.

The minimum fan speed is displayed on the ECS.

**NOTE: Upon start-up, Fan 1 will run at its maximum speed for 4 seconds.**

**This feature aids Fan 1 in attaining its set speed as quickly as possible.**

## FAN 1 DUTY CYCLE

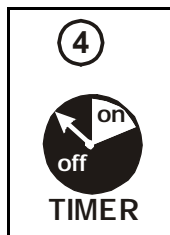

As long as the actual temperature is below the main set point, Fan 1 operates at the minimum speed set by Fan 1 Minimum Speed (primary function 3). The Fan 1 duty cycle sets the percentage of time the fan is ON versus the percentage of time the fan is OFF. The ON time is entered as a percentage of the total time which is known as the period.

The Fan 1 duty cycle is adjusted in 5% increments from a minimum setting of OFF, 5%, 10% etc., up to a maximum setting of ON corresponding to continuous operation.

**The period is fixed to 3 minutes.**

### **Adjusting the duty cycle of Fan 1:**

- rotate the Selector dial to position (4),
- rotate the Adjustor dial counterclockwise to decrease the duty cycle, clockwise to increase it.

The duty cycle is displayed on the ECS.

**Example: The duty cycle is set to 50%. As long as the main set point temperature of the room has not been reached, the fan operates at a minimum speed for 1½ minute, and OFF for 1½ minute.**

## RAMPING

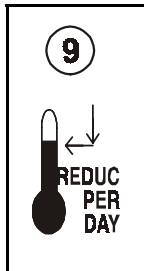

The ramping function automatically reduces the main set point by the set amount every 24 hours.

The ramping setting is adjusted in 0.01 degree decrements from a minimum setting of OFF, -0.01°F (-0.01°C) to a maximum setting of -0.99°F (-0.50°C)

**The main set point must be greater than the limit.**

### Adjusting ramping:

- rotate the Selector dial to position (9),
- rotate the Adjustor dial counterclockwise to decrease the ramping rate, clockwise to increase it.

The ramping setting is displayed on the ECS.

**NOTE: When ramping is activated or enabled, the main set point temperature cannot be manually adjusted.**

**Ramping automatically turns OFF when the minimum temperature limit is reached!**

**Example: The main set point temperature is set to 70°F and ramping is adjusted to -0.05°F. The following day the main set point temperature drops to 69.95°F followed by 69.90°F on the next. Although the main set point real value decreases, the display will be changed after 10 days. The main set point will then be 69.5°F.**

## RECORD LOW TEMPERATURE

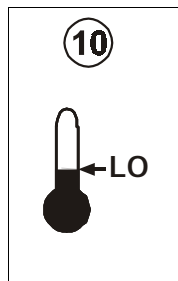

This function displays the lowest recorded temperature since the last clear.

The record low temperature is rounded to the nearest 0.5 degree from a minimum display of 13.5°F (-10.0°C) to a maximum display of 105.0°F (40.5°C). If a temperature lower than 13.5°F is recorded, Lo is displayed.

### **Viewing the lowest temperature recorded:**

- rotate the Selector dial to position (10)

### **Clearing the low temperature value**

- quickly rotate the Adjustor dial counterclockwise, then clockwise.

CLr will be briefly displayed on the ECS.

## RECORD HIGH TEMPERATURE

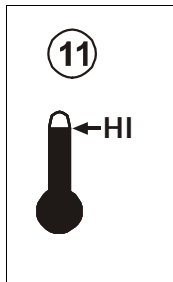

This function displays the highest recorded temperature since the last clear.

The record high temperature is rounded to the nearest 0.5 degree from a minimum display of 13.5°F (-10.0°C) to a maximum display of 105.0°F (40.5°C). If a temperature higher than 105.0°F is recorded, Hi is displayed.

### Displaying the highest temperature recorded:

- rotate the Selector dial to position (11)

### Clearing the high temperature value

- quickly rotate the Adjustor dial counterclockwise, then clockwise.

CLr will be briefly displayed on the ECS.

## AMBIENT ROOM TEMPERATURE DISPLAY

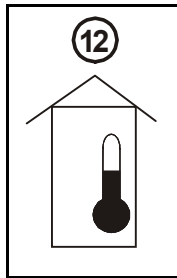

This function displays the ambient room temperature. The Selector dial should normally be left in this position.

The ambient temperature is displayed to the nearest 0.5 degree from a minimum display of 13.5°F (-10.0°C) to a maximum display of 105.0°F (41.0°C). If the temperature is lower than 41.0°F, Lo is displayed. If the temperature is higher than 105.0°F, Hi is displayed.

### **Viewing the ambient temperature:**

- rotate the Selector dial to position (12)

The ambient temperature is displayed on the ECS.

---

## SECONDARY FUNCTIONS

---

### REATIVE HUMIDITY SET POINT

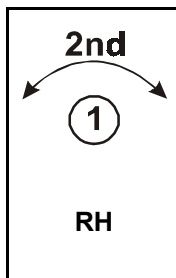

If the ECS is equipped with an optional humidity sensor, this setting regulates the humidity level of the room. The humidity setting affects the operation of Fan 1 only. When the humidity level of the room exceeds the relative humidity setting, Fan 1 runs at a new minimum speed set by secondary function (3). The fan operates at this speed as long as the ambient room temperature is below the main set point. When the temperature of the room is greater than the main set point temperature the fan speed increases until the maximum speed for the fan has been reached. The humidity level is adjusted in 1% increments from a minimum setting of 30% to a maximum setting of 80%.

**Adjusting the relative humidity level:**

- rotate the Selector dial to position (12),
- rapidly rotate the Adjustor dial back and forth to enter secondary function mode,
- rotate the Selector dial to position (1),
- rotate the Adjustor dial counterclockwise to decrease the humidity setting, clockwise to increase it.

The humidity setting is displayed on the ECS.

## FAN 1 MOTOR

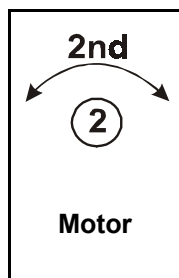

The Fan 1 motor compatibility setting adjusts the ECS 1M outputs to the electrical characteristics of the fan motor. Eight choices are available. If your motor is not listed **in the compatibility table in the Appendix**, try all choices and take the one that give the best performance with your fan. Settings 2 - 8 are the optimized settings for fan models listed in the compatibility table. Using the compatibility table, find the model number of your fan motor and take note of the fan motor compatibility number.

### **Setting the Fan 1 motor compatibility:**

- rotate the Selector dial to position (12),
- rapidly rotate the Adjustor dial back and forth to enter secondary function mode,
- rotate the Selector dial to position (2),
- rotate the Adjustor dial to select a motor curve.

The Fan 1 motor compatibility setting is displayed on ECS.



## FAN 1 MINIMUM SPEED FOR HUMIDITY

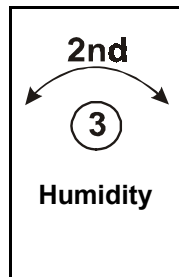

This function establishes the minimum speed of Fan 1 when the relative humidity level of the room exceeds the relative humidity setting. The speed setting for humidity must be configured higher than the speed setting for temperature. This value is entered as a percentage of maximum speed.

The Fan 1 minimum speed is adjusted in 2% increments from a minimum setting of 12% to a maximum setting of 100%.

### Adjusting the Fan 1 minimum speed for humidity:

- rotate the Selector dial to position (12),
- rapidly rotate the Adjustor dial back and forth to enter secondary function mode,
- rotate the Selector dial to position (3),
- rotate the Adjustor dial counterclockwise to decrease the speed, clockwise to increase it.

The fan 1 minimum speed setting for humidity is displayed on the ECS.

**Example: The relative humidity setting is adjusted to 65%, Fan 1 minimum speed to 25%, and Fan 1 minimum speed for humidity to 50%.**

**When the humidity level of the room reaches 65% the minimum speed of Fan 1 gradually increases to reaches 50% when the humidity level of the room is 75%.**

## FAN 1 MAXIMUM SPEED

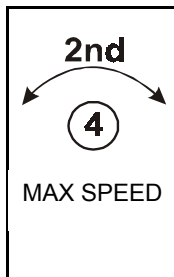

This function set the maximum speed of Fan 1 when room temperature is higher the main set point. This value is entered as a percentage of maximum speed. The Fan1 maximum speed is adjusted in 2% increments from a minimum of 60% to a maximum of 100%.

### **Adjusting the maximum speed of Fan 1:**

- rotate the Selector dial to position (12),
- rapidly rotate the Adjustor dial back and forth to enter secondary function mode,
- rotate the Selector dial to position (4),
- rotate the Adjustor dial counterclockwise to decrease the maximum speed, clockwise to increase it.

The Fan 1 speed is displayed on the ECS.

## MINIMUM RAMPING

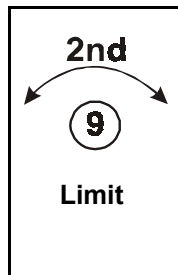

Minimum ramping is the lowest that the ramping function can adjust the main set point to. This is a security feature.

The minimum ramping setting is adjusted in 0.5 degree increments from a minimum setting of 13.5°F (-9.5°C) to a maximum setting of 105.0°F (41.0°C).

Adjusting the minimum ramping setting:  
rotate the Selector dial to position (12),  
rapidly rotate the Adjustor dial back and forth to enter secondary function mode,  
rotate the Selector dial to position (9),  
rotate the Adjustor dial counterclockwise to decrease the minimum ramping setting,  
clockwise to increase it.

The minimum ramping setting is displayed on the ECS.

**NOTE: When the main set point temperature reaches the minimum ramping limit, the ramping setting (primary function 9) automatically shuts off.**

## LOW TEMPERATURE ALARM

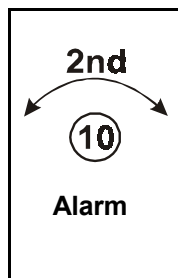

This function establishes the temperature **difference** below the main set point that the room can reach before a low temperature alarm is signalled. When a low temperature alarm occurs an alarm contact is activated and the alarm LED lights on the front panel.

The low temperature alarm is adjusted in 0.5 degree increments from a minimum setting of -32.0°F (-18.0°C) to a maximum setting of 0.0°F (0.0°C)

### **Adjusting the low temperature alarm setting:**

- rotate the Selector dial to position (12),
- rapidly rotate the Adjustor dial back and forth to enter secondary function mode,
- rotate the Selector dial to position (10),
- rotate the Adjustor dial counterclockwise to decrease the setting, clockwise to increase it.

The low temperature alarm setting is displayed on the ECS.

## HIGH TEMPERATURE ALARM

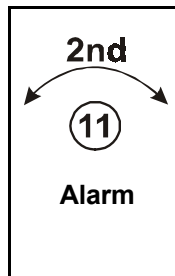

This function establishes the temperature **difference** above the main set point that the room can reach before a high temperature alarm is signalled. When a high temperature alarm occurs an alarm contact is activated and the alarm LED lights on the front panel.

The high temperature alarm is adjusted in 0.5 degree increments from a minimum setting of 0°F (0°C) to a maximum setting of 32.0°F (18.0°C)

### **Adjusting the high temperature alarm:**

- rotate the Selector dial to position (12),
- rapidly rotate the Adjustor dial back and forth to enter secondary function mode,
- rotate the Selector dial to position (11),
- rotate the Adjustor dial counterclockwise to decrease the setting, clockwise to increase it.

The high temperature alarm setting is displayed on the ECS.

## RELATIVE HUMIDITY DISPLAY

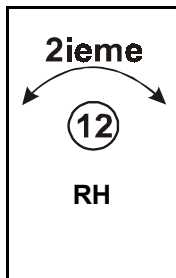

This function displays the relative humidity of the room.

Relative humidity is displayed in 1% increments from a minimum display of 30% to a maximum display of 90%. If a humidity level lower than 30% is sensed, F2 is displayed. Conversely, if a humidity level higher than 90% is sensed, Hi is displayed.

### **Displaying the humidity level:**

- rotate the Selector dial to position (12),
- rapidly rotate the Adjustor dial back and forth to enter secondary function mode.

The humidity level is displayed on the ECS.

**APPENDIX**

**MOTOR COMPATIBILITY**

<b>CURVE</b>	<b>BRAND</b>	<b>MODEL</b>	<b>VOLT</b>	<b>SIZE</b>
1	Multifan	4E40	230 v.	16"
2	Multifan	2E20	230	8"
2	Multifan	4E35	230 v	14"
2	Multifan	4E40	115 v.	16"
2	Multifan	4E40	230 v.	16"
2	Multifan	4E45	115 v.	18"
2	Multifan	4E45	230 v	18"
2	Multifan	4E50	115 v.	20"
2	Multifan	4E50	230 v.	20"
2	Multifan	AF24M'E	230 v.	24"
2	Multifan	6E63	230 v.	24"
2	Multifan	6E71	230 v.	28"
2	Multifan	8E92	230 v.	36"
2	Ziehl		115-230v	all
3	Multifan	2E30	230 v.	12"
3	Multifan	4E30	115 v.	12"
3	Multifan	4E45	230 v.	18"
3	Multifan	6E56	230 v	22"
3	Multifan/AF	AF36M	230 v.	36"
3	Leeson 1/2H	PAF20L	115 v.	20"
3	Leeson 1/2HP	AF24L	115 v.	24"
3	Aerotech-F	AT242	230 v.	24"
4	Multifan	2E25	230 v.	10"
4	Leeson 1/4HP	AF14L	115 v.	14"
4	Leeson 1/4HP	AF16L	115 v.	16"
4	Marathon 1/4HP		230 v.	16"
4	Marathon 1/3HP		230 v.	18"
4	Leeson 1/3HP	AF18L	115 v.	18"
5	GE Motor	5KCP39...	230 v.	12"
5	Leeson 1/4HP	AF12L	230 v.	12"
5	GE Motor	5KCP39...	230 v.	14"
5	Emerson	K55HXJ...	230 v.	14"
6	Oversized motors			
7	Multifan	4E30	230 v.	12"
7	Multifan	2E35	230 v.	14"
8	Multifan	4E25	230 v.	10"

## TROUBLESHOOTING

<b>SYMPTOM</b>	<b>CAUSE and REMEDY</b>
<b>Lo is continually displayed</b>	<ul style="list-style-type: none"><li>– Temperature is below minimum (13.5°F or -10.0°C).</li></ul>
<b>Hi is continually displayed</b>	<ul style="list-style-type: none"><li>– Temperature is above maximum (105.0°F or 41°C).</li><li>– Probe is short circuited.</li></ul>
<b>Fan(s) or heater not operating</b>	<ul style="list-style-type: none"><li>– Verify whether the fan LED is on. If LED is on yet fan or heater is not operating, verify wiring, fan and fuse. Refer Figure 5 for fuse location. If fuse is blown, replace with fuse of same type.</li></ul>
<b>Display is blank</b>	<ul style="list-style-type: none"><li>– Verify that the line voltage selector switch is properly set.</li><li>– Verify that the 10 pin flat cable between the main board and the faceplate board is connected.</li></ul>
<b>F2 displayed for relative humidity</b>	<ul style="list-style-type: none"><li>– Humidity is below minimum (30%).</li><li>– Probe is disconnected or defective.</li></ul>



**SPECIFICATION**

<b>DESCRIPTION</b>	<b>VALUE</b>
<b>INPUT POWER</b>	<ul style="list-style-type: none"><li>- 10 AMP</li><li>- 115/230 -20%, +10% VAC</li><li>- 50 / 60 Hz</li></ul>
<b>STAGE 1 (variable speed)</b>	<ul style="list-style-type: none"><li>- 10 AMP; inductive 115V / 230V</li><li>- Fuse 15A</li></ul>
<b>ALARM (dry relay contact)</b>	<ul style="list-style-type: none"><li>- 2 AMP; 30V AC/DC</li></ul>

## RECORD FORM

Dial	Option	Default setting		User setting
1	Main Set Point Temperature	77°F	25°C	
2	Fan 1 Differential	4°F	2°C	
3	Fan 1 Min Speed	24%	24%	
4	Fan 1 Duty Cycle Timer	ON	ON	
9	Ramping	OFF	OFF	

## 2nd Function

1	Relative Humidity	65%	65%	
2	Fan 1 Motor Compatibility	2	2	
3	Fan 1 Min Speed For Humidity	50%	50%	
4	Fan 1 Maximum Speed	100%	100%	
9	Minimum Ramping Limit	65°F	18°C	
10	Lo Temperature Limit	-9°F	-5°C	
11	High Temperature Alarm	20°F	12°C	

## *WARRANTY*

---

### **Limited Warranty**

The manufactured equipment and supplied components have gone through rigorous inspection to assure optimal quality of product and reliability. Individual controls are factory tested under load, however the possibility of equipment failure and/or malfunction may still exist.

For service, contact your local retailer or supplier. The warranty period shall be for two years from manufacturing date. Proof of purchase is required for warranty validation.

In all cases, the warranty shall apply only to defects in workmanship and specifically exclude any damage caused by over-voltage, short circuit, misuse, acts of vandalism, fortuitous events, acts of God, flood, fire, hail, lightning or any other natural disaster. Any unauthorized work, modification or repair on this product automatically voids the warranty and disclaims the manufacturer from all responsibility.

The manufacturer assumes only those obligations set forth herein, excluding all other warranties or obligations. This warranty stipulates that in all cases the manufacturer shall be liable only for the supply of replacement parts or goods and shall not be liable for any personal injury, damages, loss of profits, interrupted operations, fine contravention of the law or damages to the production of the PURCHASER and the PURCHASER shall take up the defense and hold the manufacturer faultless regarding any legal or extra legal proceedings, notice, or claim by the customer or by a third party, and regarding any legal and extra legal expenses and fees brought forward on by such damages.

MAV ECS-1M Ver: 1.01  
June 2001