

Cable Entry:
Punch holes at the bottom of the enclosure to allow wires to be introduced in the controller. Do not drill the top or side panels of the enclosure.

Mounting the Enclosure on the Wall:
Leave a clearance of at least 12" to the left of the controller to allow the cover to be removed for maintenance.

Note 1 - Toggle Switch
If the toggle switch is not required, connect up both toggle switch terminals together as illustrated.

Note 2 - Proximity Sensor
Set the delay of the proximity sensor to 0 second (no external load resistor required).

Note 3 - External Contactors
Use CSA certified and sealed contactors only !

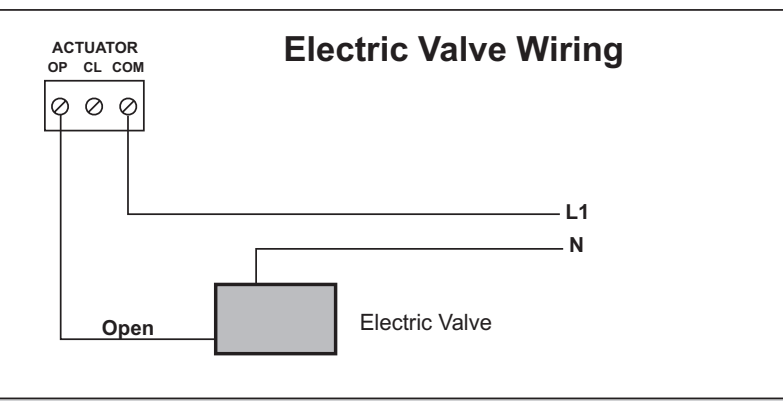
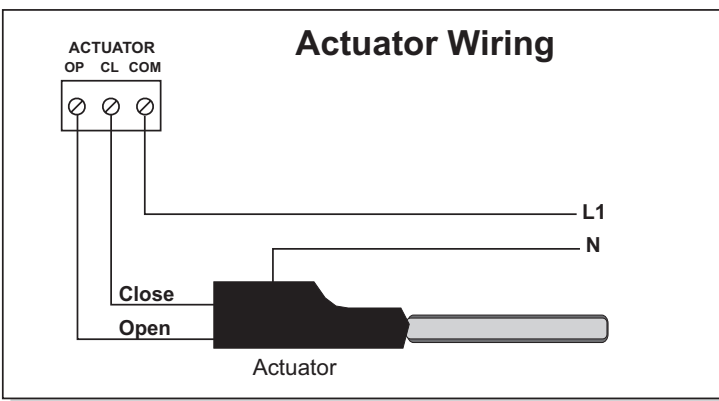

A-BOX Communication System Hook-up (Optional)

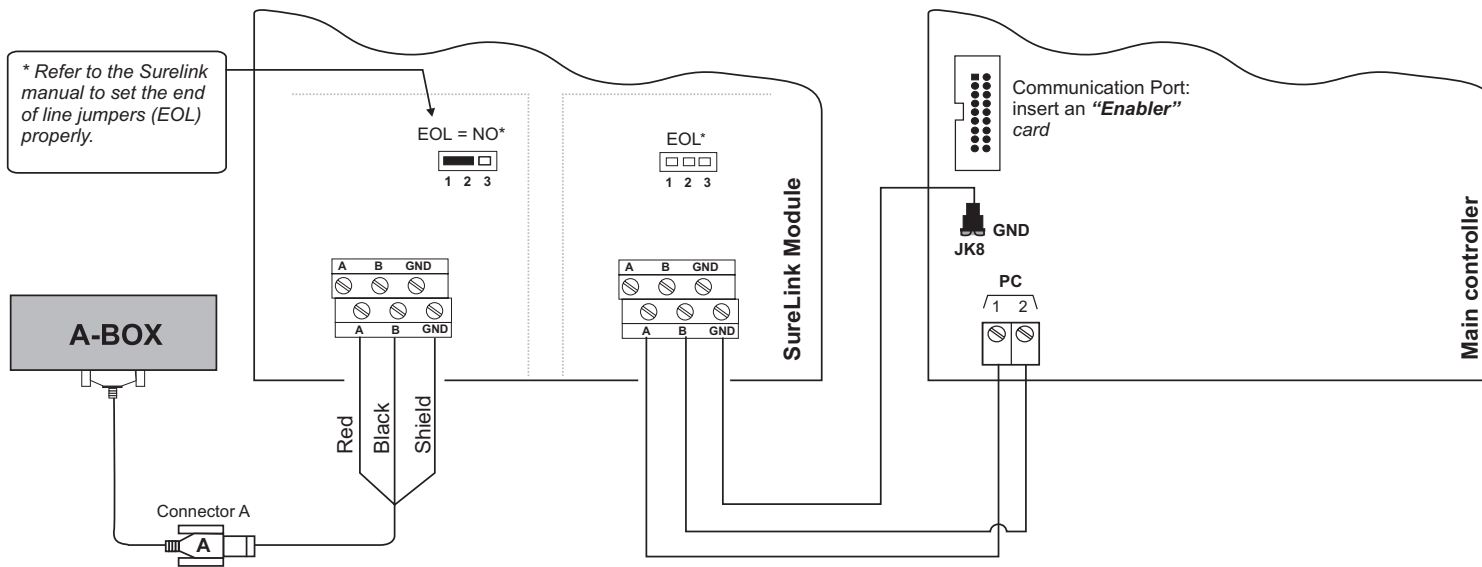

AgNet Communication System Hook-up (Optional)

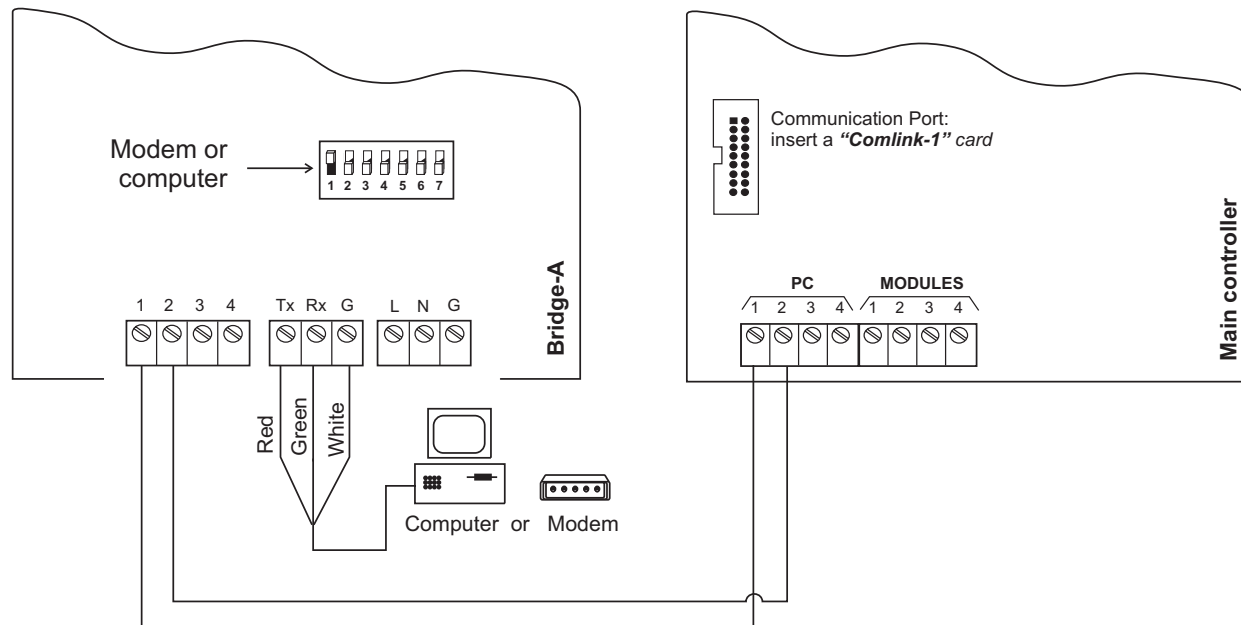

WIRING DIAGRAM

APCD-500

#891-00419

Rev.02