



HIRED-HAND®

Farm Hand 4 Stage Controller

4 Stage Environmental Controller

**Hired Hand Manufacturing, Inc.
1733 Co Rd 68
PO Box 99
Bremen, Alabama 35033**

Table of Contents

1.	Ratings and specifications	3
2.	Warnings	3
3.	Limited Warranty	3
4.	Introduction	4
5.	Day to Day Operating Instructions.....	4
5.1	Checking/Adjusting Temperatures, and Timer Percentages.....	4
5.2	Running Curtain Machines.....	5
6.	Program Mode.....	5
6.1	Stage Parameters	6
6.1.1	Stage Sensors (P1).....	6
6.1.2	Stage Mode (P2).....	6
6.1.3	Stage Timer Settings (P3).....	7
6.1.4	Stage On Points (P4)	7
6.1.5	Stage OffPoints (P5).....	7
6.2	Curtain Parameters	7
6.3	Cool Timer Settings.....	8
6.4	PC Compatible Network Parameters	9
6.5	Sensor Calibration	9
7.	Rarely Changed Settings	10
7.1	Switch Settings	10
8.	Controller Installation and Setup.....	11
8.1	Installation	11
8.1.1	Tools Required	11
8.1.2	Installation Instructions	11
9.	Programming Examples	12
9.1	Setting up a Stage	12
9.2	Setting Up Tunnel Control	12
9.3	Cool Timer Stage Operation.....	13
10.	Maintenance	15
11.	Wiring Diagrams	15
11.1	Connecting Stages to a Relay Panel	16
11.2	Connecting Equipment Directly to the Controller.....	17
11.3	Curtain Machine Wiring.....	18
11.4	Sensor Wiring.....	19
11.5	Connecting AC Power To the 4 Stage Controller	20
11.6	Connecting the 4 Stage Controller to a Data Shuttle.....	21
12.	Connecting the 4 Stage to a Series or Parallel Alarm.....	22
12.	References	23
12.1	Program Reference	23
12.2	Error Codes.....	26
12.2.1	Descriptions.....	26
12.2.2	Possible Solutions.....	26
12.3	Temperature vs. Sensor Resistance Table	27
13.	Program Parameter Listing	28
14.	Error Code Listing	28
14.	Program Data Sheet.....	29
15.	Curtain Movement Time (sec.) Vs. Distance (inches/cm.).....	30

1. Ratings and specifications

- 115/230 Volts (Depending on switch position.)
- 50/60 Hz.
- 12 Amps per stage.
- 8 Amps per curtain machine.
- Room must be kept above 32°F/0°C.

2. Warnings

Warning!

Before connecting power to the machine, be sure to check the position of the voltage selector switch located next to the transformer on the relay board. Improper positioning of this switch will cause system failure.

Warning!

When this controller is used in a life support heating and ventilation system where failure could result in loss or injury, the user should provide adequate back-up, or accept the risk of such loss or injury!

3. Limited Warranty

All products are warranted to be free from defects in material and workmanship for a period of one year from the date of purchase if installed and used in strict accordance with the installation instructions. Liability is limited to the sale price of any products proved to be defective or, at manufacturers' option, to the replacement of such products upon their return. No products are to be returned to the manufacturer, until there is an inspection and/or a return-goods authorization (RGA) number is issued.

All complaints should be directed first to the authorized distributor who sold the product. If satisfaction is not obtained or the name of the distributor is not known, write the manufacturer that appears below, directed to the attention of Customer Service Manager.

This limited warranty is expressly in lieu of any and all representations and warranties expressed or implied, including any implied warranty of merchantability or fitness for a particular purpose. The remedy set forth in this limited warranty shall be the exclusive remedy available to any person. No person has authority to bind the manufacturer to any representation or warranty other than this limited warranty. The manufacturer shall not be liable for any consequential damages resulting from the use of our products or caused by any defect, failure or malfunction of our products. (Some areas do not allow the exclusion or limitation of incidental or consequential damages, so the above limitation or exclusion may not apply to you.)

This warranty gives you specific legal rights and you may also have other rights that vary from area to area.

Warrantor:

Hired-Hand Manufacturing, Inc.
1733 Co. Rd. 68
PO Box 99
Bremen, Alabama 35033

4. Introduction

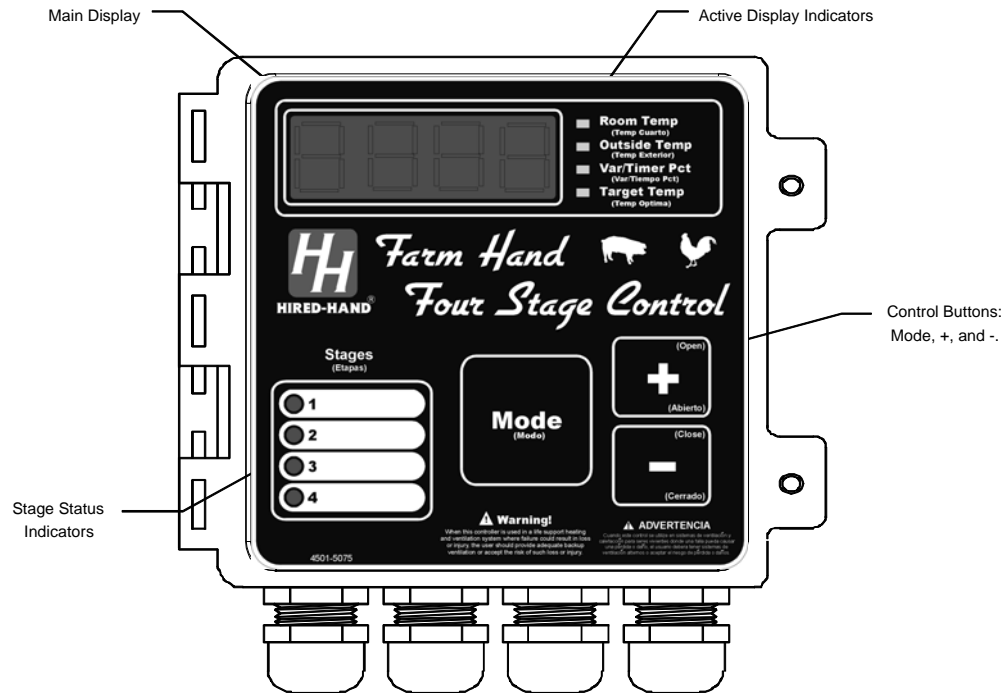

The Farm Hand 4 Stage Controller is designed to be one of the simplest controllers on the market to operate, but to also be one of the most powerful.

The 4 Stage Controller has three main regions on the facepad that you need to be concerned with. First is the main display. This section includes the main display, and four green LED's which tell what the display is indicating. If the green light beside "Room Temperature" is lit, then the display is showing the average inside temperature of your building. Later in this manual you will learn how to see the other three parameters.

On the left hand side of the controller face you will see the four stage status indicators (a small red LED on the left side of this white region). This light will be lit if the stage is on, and will flash on and off if it is running because it is on a timer. The blank white region is for you to label your equipment such as (front heat, back heat, sidewall fans, etc.).

Just below the main display on the right hand side of the controller is the control button region. This region has three buttons, Mode, +, and -. You will learn the use of these three buttons later in the manual.

5. Day to Day Operating Instructions

This section of the manual will give you all you need to know about the day to day operation of your controller.

5.1 Checking/Adjusting Temperatures, and Timer Percentages

At any time you want to see the average temperature of your house, just look at the display. When no one has pressed a button for over one minute, the display will automatically show "Room Temperature". To see the outside temperature, press the button labeled "Mode". This button is located in the center of the controller facepad. When you press the button, watch

the green LED's beside the main display. Whichever LED is lit is the parameter you are viewing. You can easily see "Outside Temperature", "Var/Timer Percentage", and "Target Temperature".

Room Temperature

The average of the sensors located inside the house.

Outside Temperature

The temperature read by the sensor located outside the house. (Sensor 3)

Var/Timer Percentage

This parameter is the percentage of the timer cycle that a stage on a timer will run.

Target Temperature

The temperature the system tries to maintain.

To adjust these settings, press the mode button until you see the setting you want to adjust. Then use the + button to raise the value, and the - button to lower the value. When you are finished setting a new value, either press the mode button again, or do nothing, and the system will return to normal operation within a few seconds.

5.2 Running Curtain Machines

Under normal circumstances the machines should be controlled automatically. This way, if the controller needs to open the curtains, it will open them. If, however, you want to open or close them for any reason do the following.

1. Press the + and - button at the same time and hold them down for 5 seconds. When the controller is in manual mode, the display will flash "PC".
2. To open the machine press the + (Open) Button
3. To close the machine press the - (Close) Button
4. Finally when you are finished positioning the machine, press both the + and - buttons at the same time, and hold them for 5 seconds.
5. The controller will take control of the curtains at this point.

6. Program Mode

Settings that are usually set up once per growout, or maybe even just for summer or winter are referred to as program parameters and are accessed by taking the controller to program mode. Some examples of these settings are Curtain Runtime, Stages on Timers, and Sensor Calibration.

To get to program mode, press and hold the "Mode" button for five seconds. When the controller has entered program mode, the main display will flash between "P1" and the value of this parameter.

The "P1" is known as a parameter number. All the program items for the controller have a parameter number assigned to them. The numbers are listed in the section called "Program Reference" in the back of this manual with a short description of each parameter.

When in the program mode, you change the current parameter by using the + and - buttons as needed. When you have finished with the current setting, press the "Mode" button to move to the next parameter.

Look at the stage status indicators. If the light for stage 1 is lit, the parameter you are programming is for stage 1. To go to stage 2, continue to press the mode button until the stage 2 indicator light is lit.

6.1 Stage Parameters

The following parameters are used to program each stage on the Farm Hand 4 Stage Controller. Through these parameters, the user has complete control over the operation of each stage. The following section explains each parameter in detail.

- P1 = Stage Sensors**
- P2 = Stage Mode**
- P3 = Stage Timer Settings**
- P4 = Stage ON Point**
- P5 = Stage OFF Point**

6.1.1 Stage Sensors (P1)

The 4 Stage Controller triggers stage operations from temperature sensors. The stage sensor parameter (P1) sets which sensor(s) the controller uses to regulate stage operation.

P1 options are as follows:

- 10 = Sensor 1**
Sensor 1 is used. The controller will ignore sensor 2.
- 02 = Sensor 2**
Sensor 2 is used. The controller will ignore sensor 1.
- 12 = Average of Sensors 1 & 2**
The average temperature of sensor 1 and sensor 2 is used.

6.1.2 Stage Mode (P2)

The 4 Stage Controller is a very intelligent controller, therefore, it needs to not only know whether this is a heating or cooling stage but also what type of cooling stage. The 4 Stage Controller reacts not only to temperature but also curtain position. This feature allows the grower to program the cooling stages to work exactly like he wants them to without the expense of hard wiring through relays and limit switches. This feature allows the 4 Stage Controller to better react to the environment. Any Stage can be programmed to be one of the following:

Important: In the following descriptions, many references are made to the Main Curtain (Unit 1). If you do not have a Main Curtain or do not wish to use the auxiliary connection as shown in section 11.3, you must place a jumper across the signal terminals for Unit 1. This manipulates the controller into thinking the main curtain is closed. In turn, this allows the heat and negative stages to operate.

- 01 = Heat**
This mode allows the equipment to operate when room temperature is below the ON Point for the stage, and the curtains are closed.
- 02 = Cool Stir**
This mode setting allows the cool stage to run whether the main curtain is open or closed. The only time that this mode will not run is during tunnel mode.
- 03 = Cool Negative**
This mode setting only allows the cooling stage to run if the main curtain is closed, hence the name Negative. This stage will not run if the controller is in tunnel mode.

04 = Cool Negative Tunnel

This mode setting works exactly like the Cool Negative setting except it will run if the controller goes into tunnel mode. This stage is sometimes referred to as a transitional stage. In other words, it operates before it goes into tunnel and also during tunnel.

05 = Cool Tunnel

This mode setting only works when the controller is in tunnel mode.

6.1.3 Stage Timer Settings (P3)

The 4 Stage Controller is equipped to satisfy any of your minimum ventilation needs for regular runtime timers, to cool timers.

00 = No Timer

Select 0 for the timer setting if you do not want the stage to be on a timer.

01 = Runtime Timers

Any one of the 4 On/Off stages can be placed on the system timer by placing a "1" in parameter 3 (P3) of the stage. By doing this the stage will operate off of the system timer while the temperature is below the stage's On Point. Once the temperature reaches the stage On Point, the stage will come on full time.

02 = Cool Timers

Any one of the 4 On/Off Stages can be placed on a cool timer. By doing this the stage will operate off the system timer only while the temperature is above the stage OffPoint (P5). Refer to section 9.3 ("Cool Timer Stage Operation") for proper setup.

6.1.4 Stage On Points (P4)

The OnPoint setting is the temperature at which a stage turns on. (i.e. the temperature at which a start signal is transmitted by the controller). The OnPoint setting of a 'cool' stage will always be greater than the target temperature. The OnPoint setting of a 'heat' stage will always be less than the target temperature. The temperature controller will automatically limit settings accordingly.

6.1.5 Stage OffPoints (P5)

The OffPoint setting is the temperature at which a stage turns off.

6.2 *Curtain Parameters*

This controller runs 1 or 2 curtain machines independently. No additional resources – including external timers – are necessary. The curtain machines run off a common cycle timer and run timer, however they can use separate sensors. The sensor selection is made via a switch located on the inside of the front cover of the machine. This switch causes the machines to either operate together or independently. If they are operating independently, unit 1 always uses sensor 1 and unit 2 uses sensor 2.

A brief overview of the programmable parameters for the curtain machines follows:

<p>Note: Parameters P20-P24 are only used when using the main curtain to naturally ventilate the building.</p>

P20 -- Cycle Time

The controller looks at all parameters and decides whether or not to move the curtains occasionally. This parameter determines how often this occurs. Valid settings are 1 to 10 minutes.

P21 -- Run Time

When the controller determines that curtains need to run open or close, this setting determines how long they run. Valid settings are 1 to 240 seconds.

P22 -- Initial Run Time

When the controller determines that the curtains should run open and senses that they are closed, it uses this parameter for the 'first' run. This setting is used to allow the curtains to open enough on the first run to guarantee adequate ventilation. Valid settings are 1 to 240 seconds.

P23 -- Degrees above target for Unit 1

Generally a grower would like to give his variable speed and/or first stage fans an opportunity to ventilate the building before starting curtains open. Thus, when the curtains do come down, they will most likely stay down for a fair period of time. This setting allows the user to do that. Valid settings are: 0 - 25.

P24 -- Degrees above target for Unit 2

Occasionally, a grower may want one curtain sidewall to drop before the other to try to avoid large temperature swings. This setting allows for this to happen. **Note: If you would like both curtain units to always react together, you must set P23 = P24.**

P25 -- Tunnel Onpoint

This is the sensor 3 temperature at which the controller will enter tunnel mode. Only applicable when tunneling on outside temperature.

P26 -- Tunnel Offpoint

This is the sensor 3 temperature at which the controller will exit tunnel mode. Only applicable when tunneling on outside temperature.

P27 -- Close Override (Degrees Below Target)

This setting provides the grower a temperature at which to override the curtains closed. The setting represents degrees below target at which time the curtains will begin closing regardless of the cycle. The setting allows the user to anticipate quick temperature drops to help maintain a stable inside temperature. Valid settings are 1-25.

6.3 Cool Timer Settings

The following two settings allow the user to set the Runtime range for their cool timer stages.

P70 = Cool Timer Maximum Percentage

This sets the maximum Runtime percentage that a cool timer stage can operate.

P71 = Cool Timer Minimum Percentage

This sets the minimum Runtime percentage that a cool timer stage can operate.

6.4 **PC Compatible Network Parameters**

This option requires Hired-Hand's Farm Manager Software. The controller has 3 functions which are used to set it up on the Hired-Hand PC compatible inter-controller network (HHNet). These are:

P40 - HHNet Address

HHNet allows you to connect up to 32 controllers on a single communications port of your personal computer (PC). In order for the computer to recognize the communications from the controllers, each controller must have a unique address. For example: If you have two *4 Stage Controllers*, and two *Power Vents* you would need to set the first *4 Stage Controller* to be address 1, the second *4 Stage Controller* to address 2, the first *Power Vent* to address 3, and the second *Power Vent* to address 4. Valid settings are: 1 - 32. (You do not have to address the controllers in any particular order.)

P41 -- Version Number

This is not settable. It is the version of controller software.

P42 -- Controller Type

This is not settable. It is a unique number which allows the network software (Farm Manager) to know what type controller it is.

6.5 **Sensor Calibration**

The 4 Stage Controller has 3 sensors which may be calibrated. The parameter(s) for calibration are PSx with x being the sensor number. The sensor temperature reading is alternately displayed along with the parameter number.

You should never attempt to calibrate a sensor more than 8 degrees. If you have a setting that far out of range, it indicates that there is a problem which should be corrected.

PS1 - Calibrate Sensor 1

This reading can be changed by pressing the + or - button until the desired reading is displayed.

PS2 - Calibrate Sensor 2

This reading can be changed by pressing the + or - button until the desired reading is displayed.

PS3 - Calibrate Sensor 3

This reading can be changed by pressing the + or - button until the desired reading is displayed.

7. Rarely Changed Settings

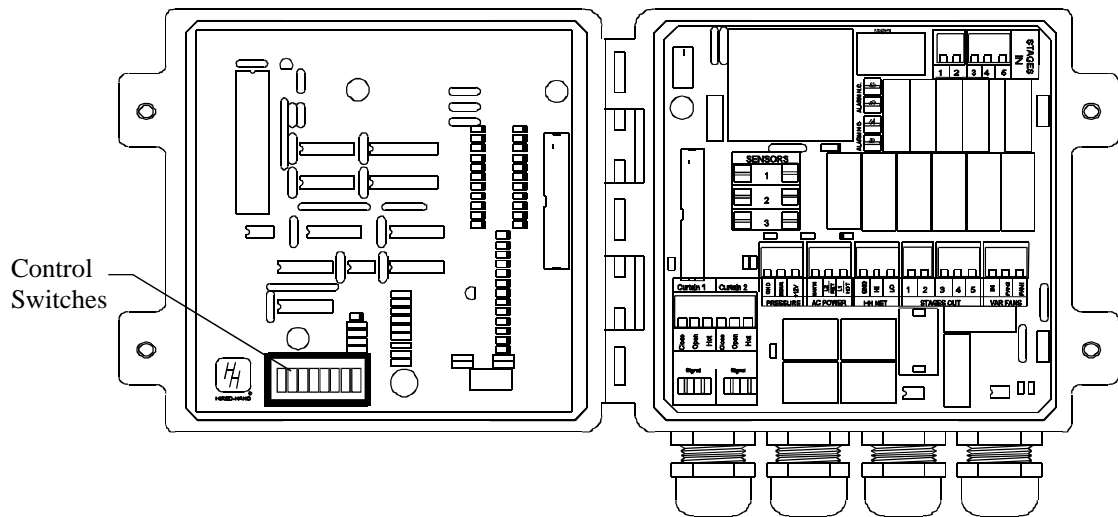

Settings which are rarely or never changed are found on a bank of switches located inside the front panel of the controller. The upper position is ON, the lower position is OFF. Switches number from left to right. The functions of the switches are as follows:

7.1 Switch Settings

SWX 1 - Lock

This switch is used to lock the controller. When it is on, the user may change settings such as target temperature and minimum speed/timer percentages but they can not change the settings in program mode. If the switch is set to ON the program settings are locked.

SWX 2 - Fahrenheit/Celsius

This switch toggles between Fahrenheit and Celsius operation. If the switch is set to ON, the controller will read the sensors as Fahrenheit. (Note: If you change this switch, you will have to reset your tunnel on points and off points and your Target Temperature.)

SWX 3 - 5/10 minute timer

This switch selects between a 5 and 10 minute system timer. If the switch is ON, the timer is 10 minutes.

SWX 4 - Curtains independent

This switch is used to choose whether the curtain machines operate off the same sensor or if they operate independently. If the switch is ON, the curtains are independent with curtain 1 running on sensor 1, and curtain 2 running on sensor 2.

SWX 5 - Tunnel On/Off

This switch is used to enable or disable the tunnel mode of the controller. When this switch is in the OFF position, the controller will not go into tunnel for any reason.

SWX 6 - Tunnel On Stage

This switch tells the controller whether it is tunnelling off of the lowest programmed tunnel stage or if it is tunnelling off of outside temperature. If this switch is set to the ON position, the controller will switch to tunnel mode whenever

the first programmed tunnel stage comes on. If this switch is OFF, the controller will use the “Tunnel On Point” setting for entry into tunnel.

SWX 7 - Power Ventilate

This switch indicates whether this is a power ventilated house or a natural ventilated house. If it is a power ventilated house the controller will leave the inlet curtain closed until tunnel mode is entered. This switch must be set to ON if you have a Power Ventilated house.

SWX 8 - Program ‘A’ or ‘B’

This switch is used to toggle between 2 preset programs. This could be used to store separate summer/winter programs for instance. The ON position is for Program A, and the OFF position is for Program B.

8. Controller Installation and Setup

8.1 Installation

8.1.1 Tools Required

Mini Screwdriver	Standard Screwdriver
Wire Strippers	

8.1.2 Installation Instructions

1. Unpack system, and check that all components are present.
 - 1 Farm Hand 4 Stage Controller
 - 1 Installation Kit
 - 1 Fuse Kit
 - 3 Sensors
 - 1 Manual
2. Hang Farm Hand 4 Stage Controller with four screws and the plastic mounting brackets included.
3. Make sure all power supplies are disconnected before breaking any wires, or reaching into the enclosure.
4. Open 4 Stage Controller Finisher and find all connections. Refer to wiring diagrams in back of this manual.
5. Run sensors out to locations inside the house. (Sensor 3 should be installed outside the house.) Be sure that the sensors are in a safe location, free from any temperature influences (direct sunlight, water, etc.) Use care when securing sensor wires so that you do not cut the wire, Any short, or break in the wire will cause improper sensor operation.
6. Connect each sensor to its appropriate terminals inside the enclosure. (See wiring diagrams in the back of this manual.)
7. Connect wires from stage terminals to the contactor panel, or relay box. See wiring diagrams for locations of terminals.
8. Hookup three wire connections from 4 Stage Controller board to curtain machines. See wiring diagrams for locations of terminals.

9. **CHECK THE POSITION OF THE VOLTAGE SELECTOR SWITCH.**
Connect the wires for 120/240V power to the terminals specified in the wiring diagram.

9. Programming Examples

When following these examples, you will need to refer to the Program Reference section to see which options are available for each of the parameters(P1, P24, etc.).

9.1 Setting up a Stage

There are five parameters used in programming any stage. They are P1-P5. The following is an overview of how to program a stage:

1. Enter *Program Mode* by pressing and holding the *Mode* button for 5 seconds until **P1** is displayed. This parameter selects the sensor(s) that this stage watches for on/off operation.
2. Press the + or - button until the desired sensor is displayed. 10= sensor 1; 02 = sensor 2, and 12 = an average of sensors 1 and 2.
3. Press the *Mode* button again and **P2** is shown. This parameter selects what mode the stage operates as.
4. Press the + or - button until the desired mode is displayed.
5. Press the *Mode* button until **P3** is displayed. This parameter allows you to put a stage on the system timer (5 or 10 minutes).
6. Press the + or - button until the desired setting is displayed. (0 = Not on a timer, 1 = On the timer, 2 = Cool timer).
7. Press the *Mode* button until **P4** is displayed. This parameter sets the stage On Point.
8. Press the + or - button until the desired setting is displayed.
9. Press the *Mode* button until **P5** is displayed. This parameter sets the stage Off Point.
10. Press the + or - button until the desired setting is displayed.
11. Exit Program Mode by pressing the *Mode* button until after **PS3** has been displayed or wait 1 minute.

9.2 Setting Up Tunnel Control

Note: If you do not want the controller to ever enter tunnel mode just make sure that the Tunnel On/Off switch is in the off position and you can ignore this section.

The 4 Stage Controller is a very versatile tunnel controller. It provides the grower with many different ways to tunnel based on the layout of the house. It also provides two different ways of initiating tunnel mode. The following are some tips and examples of setting up this controller to tunnel your house appropriately.

1. The first step in setting up your tunnel house is to configure the stages that you want as your **cool tunnel stages**. If some stages need to operate in tunnel mode and in normal mode, then program these stages to be **cool negative tunnel stages**. See the Program Reference section in the back of this manual for more information on the operation of various stage modes.

2. The next step in setting up your tunnel house is determining how your controller should operate while out of tunnel mode. In other words, does your house always power ventilate or does it naturally ventilate using curtain sidewalls. If it is a power ventilated house you must set the **Power Ventilate** switch (SWX-7) in the on position.
3. The last step in setting up your tunnel house is determining how you would like to initiate tunnel mode. You can initiate tunnel mode by outside temperature or by your lowest programmed **cool tunnel** stage. The lowest programmed cool tunnel stage is determined by the lowest onpoint. If you would like to tunnel based on outside temperature you must set the **Tunnel On Stage** (SWX-6) switch to off. You can then set the temperature at which you would like to enter tunnel mode at **P25** and the temperature at which you would like to exit tunnel mode at **P26**. Otherwise, set the **Tunnel On Stage** (SWX-6) to on.

The following is a brief description of how the tunnel would work in each of the situations.

Tunneling on outside temperature in a naturally ventilated building

When the outside temperature rises above the Tunnel Onpoint (**P25**), the controller will shut down all stages and begin to close the main curtain and open the inlet curtain. After 1 minute has passed, the controller makes sure that the inlet is open. If there is no error condition, the controller will begin waiting for the main curtain to close. If the controller does not see the main curtain closed after 12 more minutes, it will abort tunnelling, and sound the alarm. Once the controller recognizes that the main curtain is closed, it will then allow the other cool tunnel and cool negative tunnel stages to come on. Once the temperature drops below the Tunnel Offpoint (**P26**), the controller will open both the inlet and the main curtain fully and return the stages to normal operation immediately.

Tunneling on a stage in a power ventilated building

As soon as the lowest programmed Cool Tunnel stage comes on, the controller opens the inlet curtain and leaves all Cool Negative Tunnel and Cool Tunnel stages on. When the temperature begins to fall and the lowest programmed Cool Tunnel stage turns off, the controller will close the inlet fully and return the stages to normal operation immediately.

Tunneling on outside temperature in a power ventilated building

The controller reacts in the same way as in the previous example, except it uses **P25** and **P26** to enter and exit tunnel. For proper operation in a house without a curtain sidewall, you must jumper the curtain closed switches on the main curtain together.

Note: If you are using a main sidewall curtain, it must run at a speed where it can go from fully open to fully closed in less than 13 minutes. If not, the controller will not operate properly as tunnel.

9.3 Cool Timer Stage Operation

On all 4 Stage Controllers, any of the 4 ON/OFF stages can be placed on a cool timer. A cool timer stage will come on and run at the timer percentage whenever temperature is above it's OffPoint (**P5**), and its timer percentage will increase as temperature rises. The following graph shows how you can vary this percentage.

Refer to Graph 1 and Table 1. The stage is placed on a cool timer by setting **P3=2**. A Cool Timer stage always varies its runtime based on the stage's temperature and its **P4** and **P5** settings. In this example, the OffPoint is set to 80°F (**P5=80**), and the OnPoint is set to 86°F

(P4=86). The stage will not run if the temperature is below the OffPoint, as shown in Graph 1. When the temperature reaches the OffPoint, the stage is placed on the system timer.

To enhance temperature control, the Runtime percentage of a cool timer stage can be varied. The percentage of the Runtime that the cool timer stage is ON can be varied when the temperature is between the OffPoint and the OnPoint by setting parameters P70 and P71. In this example, the Minimum Runtime percentage is 50%, as set by **P71 = 50**. The Maximum Runtime percentage is 90%, as set by **P70 = 90**.

When the temperature reaches 80°F the stage runs for 50% of the Runtime period (2-1/2 minutes if the system timer is set for 5 minutes, or 5 minutes if the system timer is set for 10 minutes). As the temperature increases, the Runtime percentage of the stage progressively increases up to the Maximum Runtime percentage of 90% when the temperature reaches 86°F. Above 86°F, the Runtime percentage remains constant at 90%.

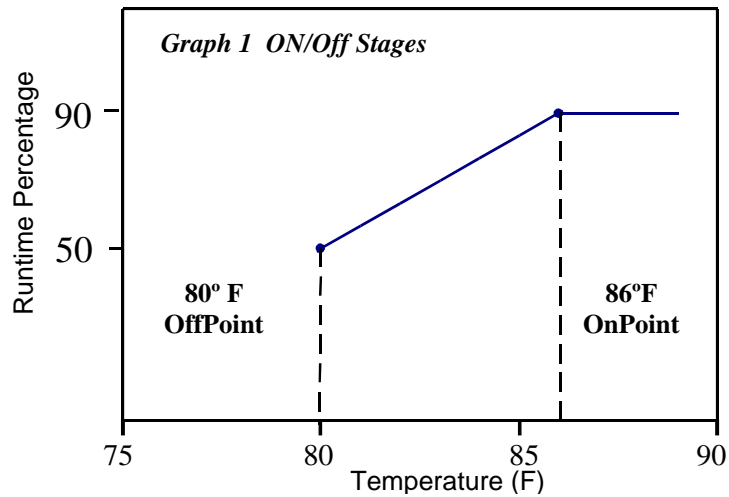

Table 1 Example Of Cool Timer Stage Operation

Setting	Stage Sensor	Stage Mode	Stage Timer	OffPoint	OnPoint	Cool Timer Max %	Cool Timer Min %
Parameter	P1	P2	P3	P5	P4	P70	P71
Value	10	02	02	80	86	90	50
Option	Sensor 1	Cool Stir	Timer ON	Minimum OnPoint	Maximum OnPoint	Minimum Runtime %	Maximum Runtime %

Brief Description Of Cool Timer Stage Operation

As you can see, a stage will be placed on the system timer once the temperature rises above 80°F (**P5**) and will start running 50% (**P71**) of the time. If the temperature continues to increase then the run time percentage will also increase toward 90% (**P70**).

10. Maintenance

Check the calibration of your sensors at least once per quarter. To do this, you will need to have two persons. One at the sensor with a trusted thermometer, and one at the controller to set the sensor to the proper setting.

11. Wiring Diagrams

All wiring connections for stages, curtain machines, variable speed fans, and curtain sensors inside the controller are made without terminals on the end of the wire. To make the connection, strip about ¼” of the insulation off the wire, and follow the diagram below.

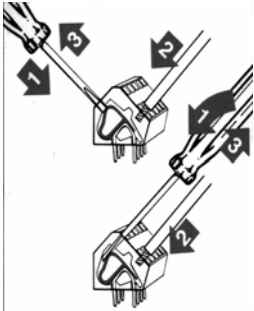

1. Insert a small screwdriver into either the hole shown in the diagram.
2. Insert the stripped end of the wire into the hole shown in the diagram.
3. Remove the screwdriver, and tug slightly on the wire to check that it is snug.

Warning!

Do not connect more than twelve (12) amps of load to any one stage.

11.1 Connecting Stages to a Relay Panel

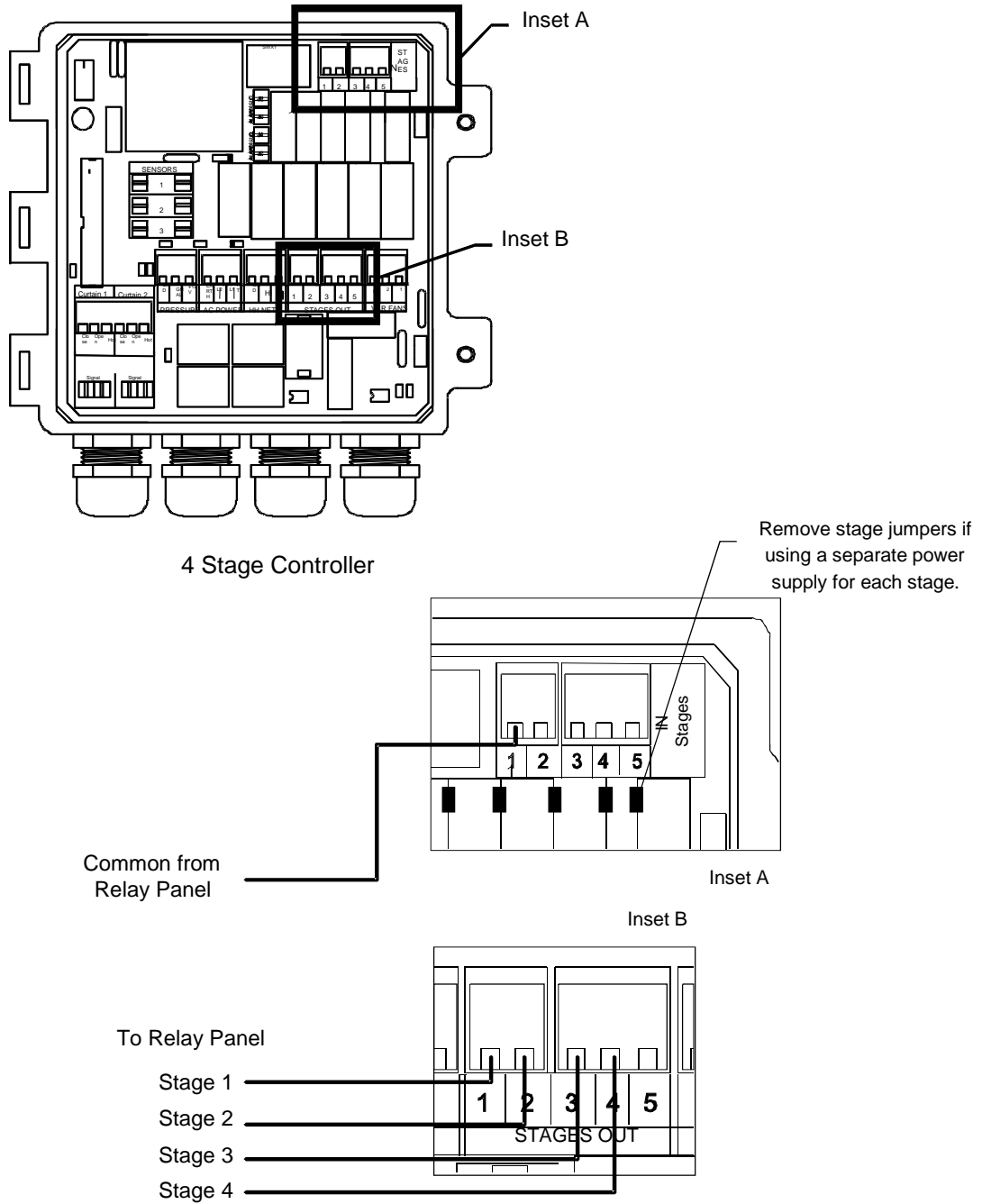

11.2 Connecting Equipment Directly to the Controller

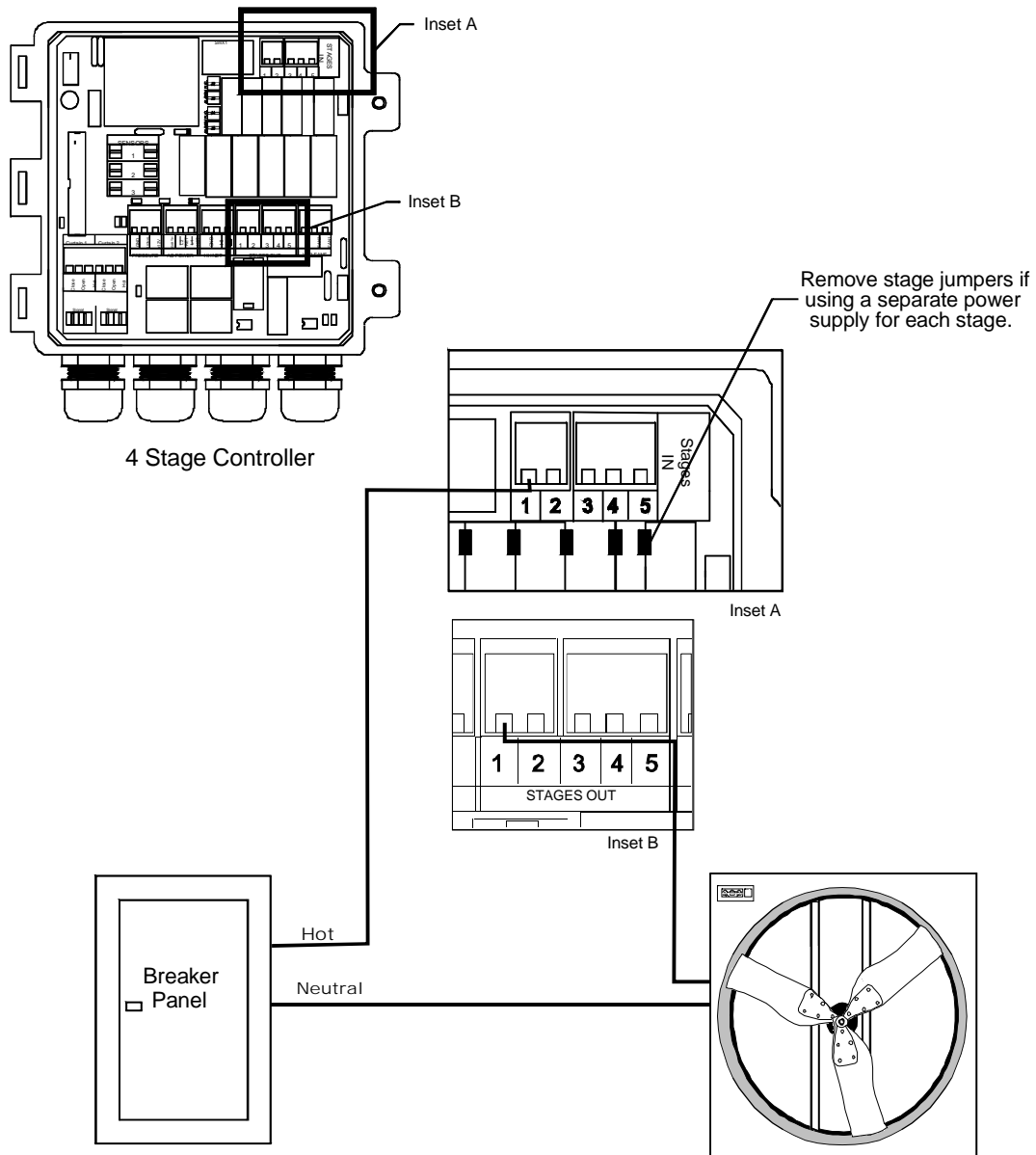

Warning: Do not connect more than 12 amps of load to a single stage!

Warning: Check that the stage jumpers are removed when connecting a load directly to the controller.

Note: Hired-Hand, Inc. recommends the use of an external contactor or relay panel to drive equipment.

11.3 Curtain Machine Wiring

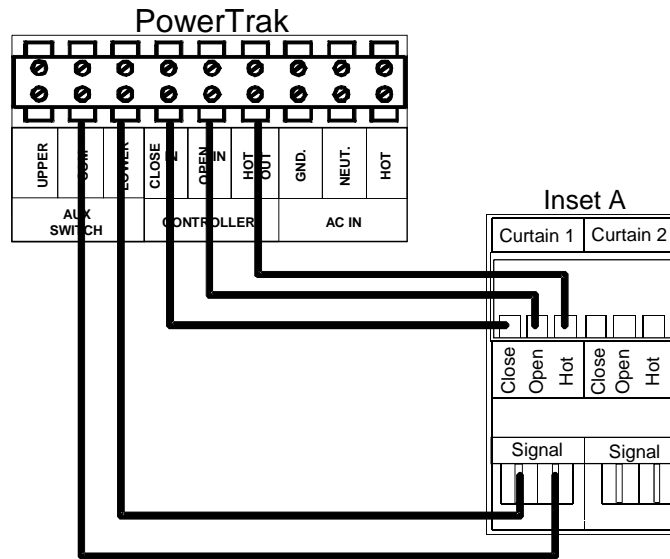
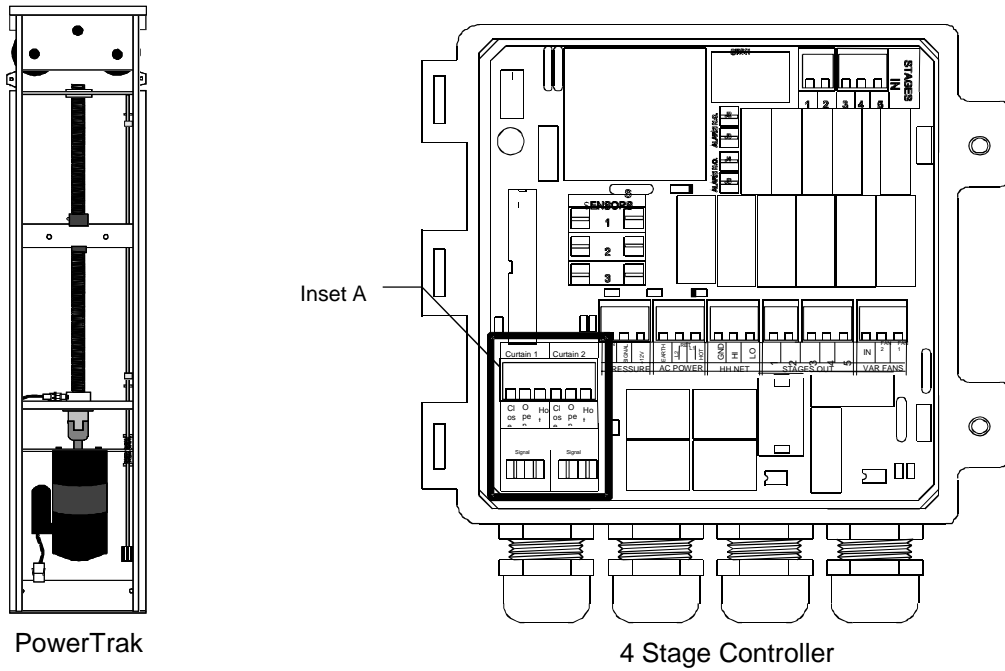

Note: If you are tunnelling with this controller, the inlet machine must be connected to "Curtain 2". Your main curtain should be connected to "Curtain 1"

11.4 Sensor Wiring

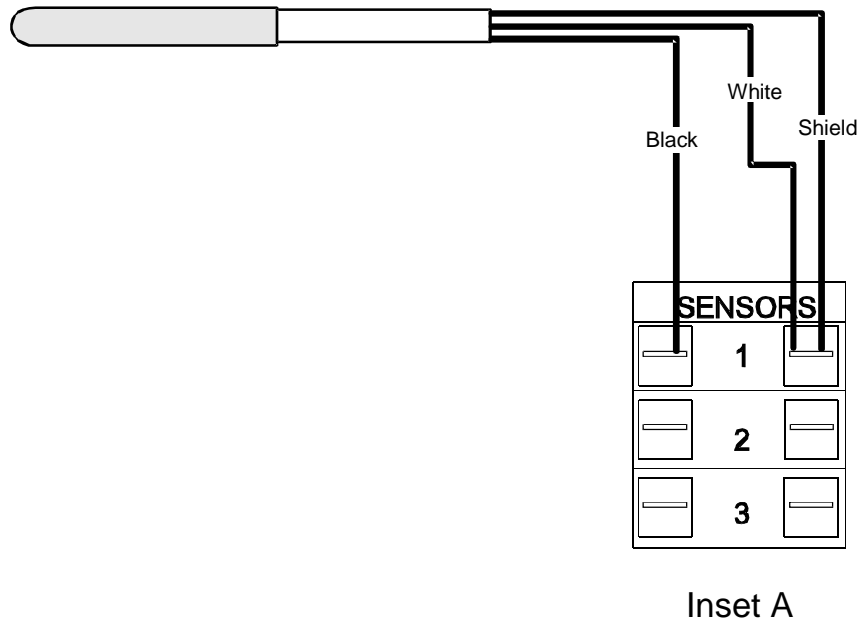
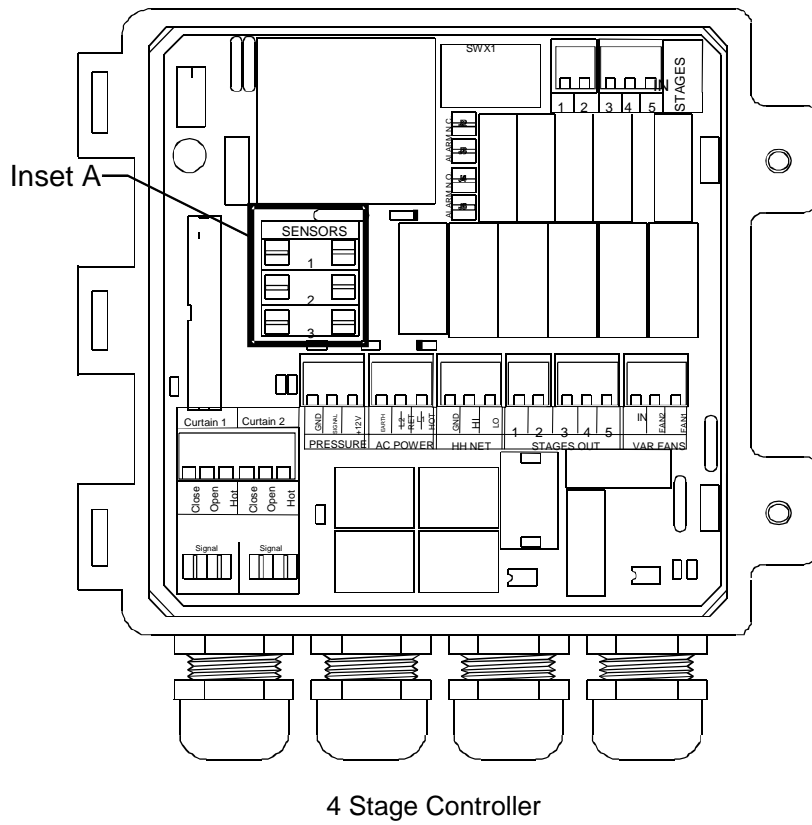

11.5 Connecting AC Power To the 4 Stage Controller

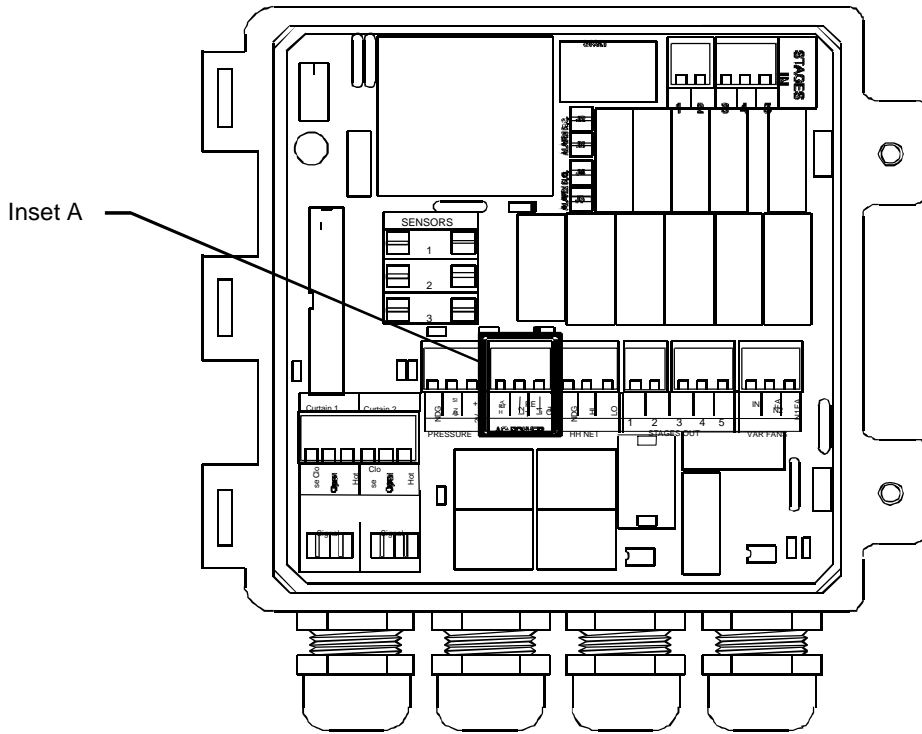

4 Stage Controller

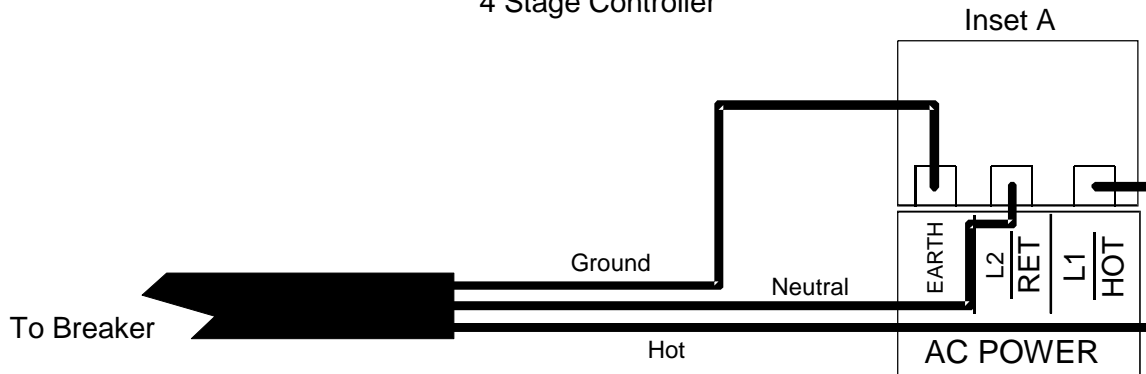

11.6 Connecting the 4 Stage Controller to a Data Shuttle

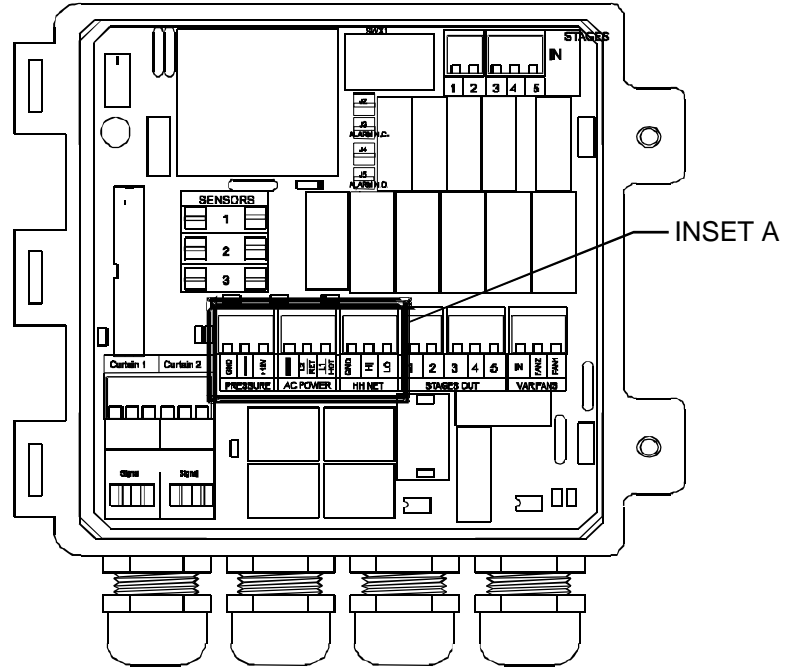

4 Stage Controller

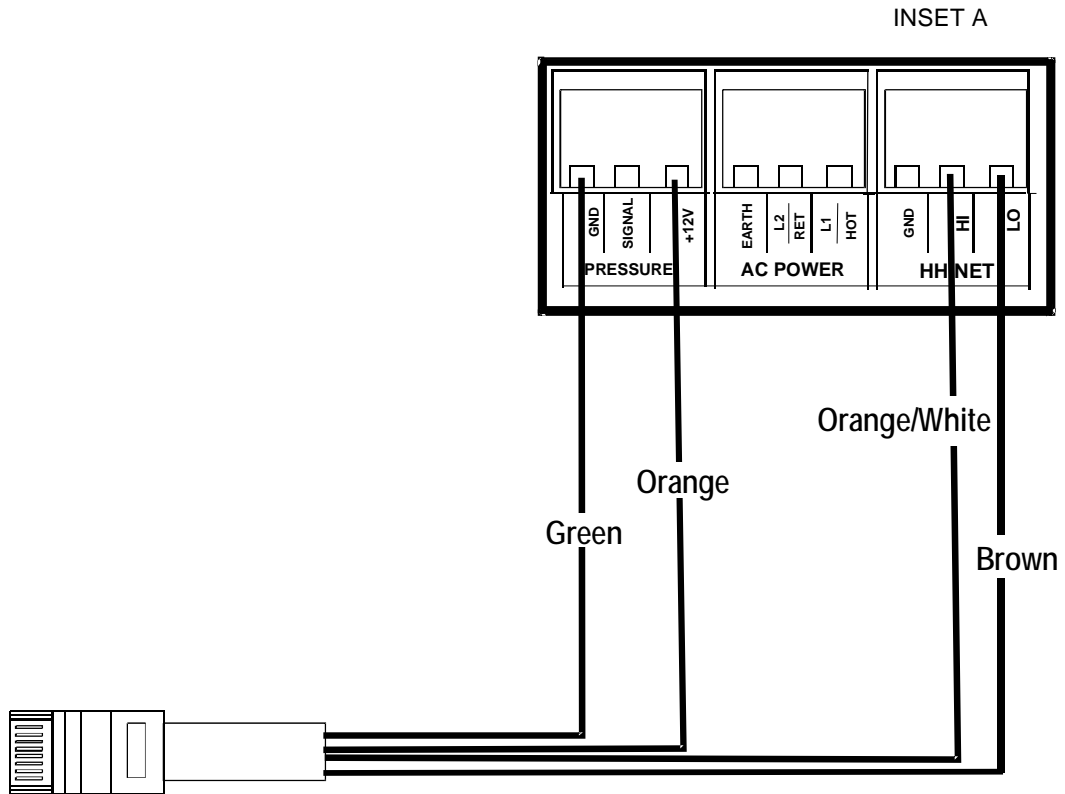

12. Connecting the 4 Stage to a Series or Parallel Alarm

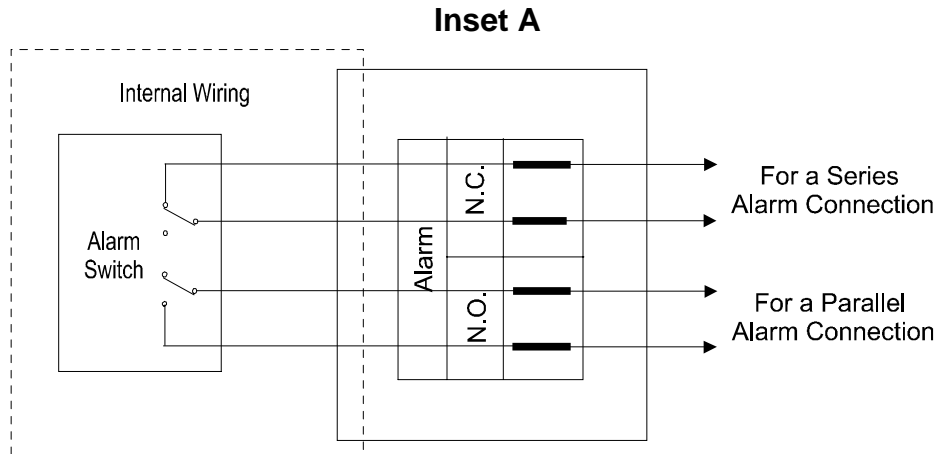
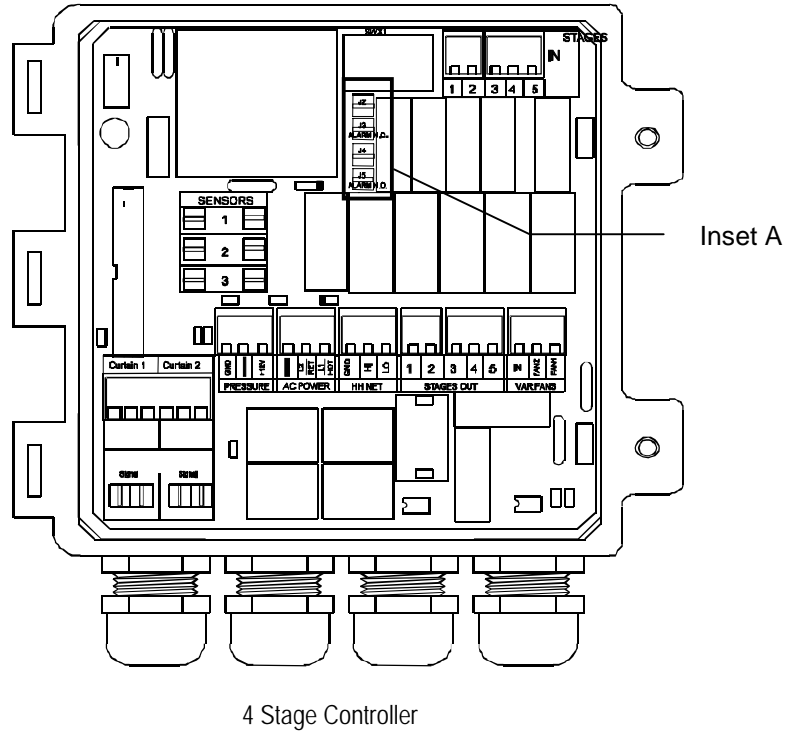

Note: The internal wiring shows the condition of the alarm relay during normal conditions (no alarm present). During an alarm condition, the contact positions will be reversed.

12. References

12.1 Program Reference

Program Parameters

P1 -- Stage Sensor	The combination of sensors used to determine whether that stage should be on or off. 10 = Stage uses sensor 1 02 = Stage uses sensor 2 12 = Stage uses an average of both sensors 1 & 2
P2 -- Stage Mode	Heat, Cool Negative, etc. This setting determines when the stage is allowed to run, and how the stage will run. 1 = Heat Mode 2 = Cool Stir Mode 3 = Cool Negative Mode 4 = Cool Negative Tunnel Mode 5 = Cool Tunnel Mode
P3 -- Stage on Timer	Any cool stage can be placed on the system timer. This timer is settable to 5 or 10 minutes. Any stage on a timer will run for the system runtime percentage. (Example: 30% runtime of 10 minutes = 3 minutes out of each ten.) 0 = No Timer 1 = Standard Timer 2 = Cool Timer
P4 -- Onpoint	The temperature at which a stage will turn on.
P5 -- Offpoint	The temperature at which a stage will turn off.
P20 -- Cycle Time	The length of time in minutes between the start of one curtain position adjustment, and the start of the next curtain position adjustment. (Cycle time of 3 means that the curtain will move up or down (or remain stationary) depending upon temperature for its runtime once every 3 minutes.)
P21 -- Run Time	The number of seconds that the curtain machine will run opening or closing at the beginning of each curtain cycle (See Cycle Time).
P22 -- Initial Run Time	Number of seconds to run on the first drop from closed. This is to be sure that you have cleared the top of the opening. This setting only applies when the controller senses that the curtain is closed when it begins its run.
P23 -- Degrees above target (Unit 1)	Many times it is more cost effective to bring a slightly high temperature back into range with a fan. This setting allows you to specify a number of degrees above the target temperature that the curtain will allow before trying to open.

P24 -- Degrees above target (Unit 2)	Occasionally, a grower may want one curtain sidewall to drop before the other to try to avoid large temperature swings. This setting allows for this to happen. Note: If you would like both curtain units to always react together, you must set P23=P24.
P25 -- Tunnel Onpoint	This is the sensor 3 temperature at which the controller will enter tunnel mode. Only applicable when tunneling on outside temperature.
P26 -- Tunnel Offpoint	This is the sensor 3 temperature at which the controller will enter tunnel mode. Only applicable when tunneling on outside temperature.
P27 -- Close Override	The degrees below target at which time the curtains will override to close.
P40 - HHNet Address	Unique setting for controllers along a single network wire pair. Only used with the PC compatibility feature using Hired-Hand's Farm Manager software.
P41 -- Version Number	This is the version of the software for the controller. This value is not settable.
P42 -- Controller Type	This is a number that identifies the type of controller (4 Stage Controller) to the Farm Manager Software (PC compatible)
PS1 - Calibrate Sensor 1	The temperature the controller reads from Sensor 1. This setting is used only when calibrating sensors. Press the + and/or - buttons until the correct reading is seen in the main display. (See Sensor Calibration)
PS2 - Calibrate Sensor 2	The temperature the controller reads from Sensor 2. This setting is used only when calibrating sensors. Press the + and/or - buttons until the correct reading is seen in the main display. (See Sensor Calibration)
PS3 - Calibrate Sensor 3	The temperature the controller reads from Sensor 3. This setting is used only when calibrating sensors. Press the + and/or - buttons until the correct reading is seen in the main display. (See Sensor Calibration)

Status Switches (Located inside the Controller Door)

SWX 1 - Lock	Locks the front panel to protect your settings from accidental change. If the switch is set to ON the program settings are locked.
SWX 2 - Fahrenheit or Celsius	Switches the temperature readings from Fahrenheit to Celsius. If the switch is set to ON the controller will read the sensors as Fahrenheit. (Note: If you change this switch, you will have to reset your tunnel on points and off points and your Target Temperature.)
SWX 3 - 5/10 minute timer	This switch selects between a 5 and 10 minute system timer. If the switch is on, the timer is 10 minutes.
SWX 4 - Curtains On Separate Sensor	This switch is used to choose whether the curtain machines operate off the same sensor or if they operate independently. If the switch is on, the curtains are independent with curtain 1 running on sensor 1, and curtain 2 running on sensor 2.
SWX 5 - Tunnel On/Off	Enables/Disables tunnel mode When this switch is in the off position, the controller will not go into tunnel for any reason.
SWX 6 - Tunnel On Stage	Option to have the controller go into tunnel whenever the first tunnel stage turns on. If this switch is off, the controller will use the "Tunnel On Point" setting for entry into tunnel.
SWX 7 - Power Ventilate	If you have a power ventilated house the controller will leave the inlet curtain closed until tunnel mode is entered. This switch must be set to "on" if you have a Power Ventilated house.
SWX 8 - Program 'A' or 'B'	This switch is used to toggle between 2 preset programs. This could be used to store separate summer/winter programs for instance. The ON position is for Program A, and the OFF position is for Program B.

12.2 Error Codes

12.2.1 Descriptions

If your controller is displaying an “E1”, or “E2”, etc. the controller has recorded an error. The controller records errors from sensor readings, and tunnel related problems. To diagnose your controller problem, look up the error on the table (under “Error Codes”) and look across the table to find the components that have failed. (Items with an “x” have failed according to the controller.)

Error Code	Description	Sensor 1 Error	Sensor 2 Error	Sensor 3 Error	Tunnel Error
E1	Sensor 1 Error	X			
E2	Sensor 2 Error		X		
E3	Sensor 1 & 2 Error	X	X		
E4	Sensor 3 Error			X	
E5	Sensor 1 & 3 Error	X		X	
E6	Sensor 2 & 3 Error		X	X	
E7	Sensor 1,2 & 3 Error	X	X	X	
E16	Tunnel Error				X
E17	Tunnel and Sensor 1 Error	X			X
E18	Tunnel and Sensor 2 Error		X		X
E19	Tunnel and Sensor 1 & 2 Error	X	X		X
E20	Tunnel and Sensor 3 Error			X	X
E21	Tunnel and Sensor 1 & 3 Error	X		X	X
E22	Tunnel and Sensor 2 & 3 Error		X	X	X
E23	Tunnel and Sensor 1,2 & 3 Error	X	X	X	X

12.2.2 Possible Solutions

Sensor Error

If any of the sensors are bad try the following:

- Reset the controller by taking power away at the breaker, or unplugging it.
- Determine which sensor is bad, then check the connection inside the controller door.
- Determine which sensor is bad, then check the sensor that is hanging in the house to make sure that it has not been damaged.
- Check the wire going to the sensor(s) to be sure there are no staples through the wires.
- Replace the bad sensor.

Tunnel Error

The controller will error if it can not open the inlet curtain or if you are using a main curtain, it will error if it can not close the main curtain.

Note: If not using a main curtain, you must put a jumper wire across the main curtain closed signal inside the control box.
--

If you see a tunnel error, check the following:

- Make sure that the inlet is operating correctly.
- If applicable, make sure the main curtain is operating correctly.
- Make sure that the curtain closed signals inside the control box are wired to the auxiliary switches inside the PowerTrak.

12.3 Temperature vs. Sensor Resistance Table

The following chart gives the resistance when measured between the white and black sensor wires at a given temperature. To check a sensor, first know the temperature in the area, then, use a multi-meter to check the resistance.

Resistance Kohms	Temp (F)	Temp (C)	Resistance Kohms	Temp (F)	Temp (C)	Resistance Kohms	Temp (F)	Temp (C)
32.654	32	0	15.714	59	15	8.59	83.3	28.5
32.158	32.5	0.3	15.568	59.4	15.2	8.517	83.7	28.7
31.671	33.1	0.6	15.353	59.9	15.5	8.408	84	28.9
31.191	33.6	0.9	15.211	60.3	15.7	8.336	84.6	29.2
30.72	34.2	1.2	15.001	60.8	16	8.23	85.1	29.5
30.257	34.7	1.5	14.863	61.2	16.2	8.125	85.6	29.8
29.802	35.2	1.8	14.658	61.7	16.5	8.056	86	30
29.355	35.8	2.1	14.457	62.2	16.8	7.954	86.5	30.3
28.915	36.3	2.4	14.325	62.6	17	7.853	87.1	30.6
28.482	36.9	2.7	14.128	63.1	17.3	7.787	87.4	30.8
28.057	37.4	3	13.999	63.5	17.5	7.689	88	31.1
27.777	37.8	3.2	13.808	64	17.8	7.592	88.5	31.4
27.363	38.3	3.5	13.682	64.4	18	7.496	89.1	31.7
26.957	38.8	3.8	13.496	64.9	18.3	7.433	89.4	31.9
26.557	39.4	4.1	13.373	65.3	18.5	7.34	90	32.2
26.164	39.9	4.4	13.192	65.8	18.8	7.248	90.5	32.5
25.777	40.5	4.7	13.073	66.2	19	7.157	91	32.8
25.523	40.8	4.9	12.896	66.7	19.3	7.098	91.4	33
25.147	41.4	5.2	12.779	67.1	19.5	7.009	91.9	33.3
24.777	41.9	5.5	12.607	67.6	19.8	6.922	92.5	33.6
24.413	42.4	5.8	12.493	68	20	6.836	93	33.9
24.055	43	6.1	12.325	68.5	20.3	6.779	93.4	34.1
23.82	43.3	6.3	12.215	68.9	20.5	6.695	93.9	34.4
23.472	43.9	6.6	12.051	69.4	20.8	6.612	94.5	34.7
23.13	44.4	6.9	11.943	69.8	21	6.531	95	35
22.793	45	7.2	11.783	70.3	21.3	6.45	95.5	35.3
22.572	45.3	7.4	11.678	70.7	21.5	6.371	96.1	35.6
22.244	45.9	7.7	11.522	71.2	21.8	6.319	96.4	35.8
21.922	46.4	8	11.42	71.6	22	6.241	97	36.1
21.71	46.8	8.2	11.268	72.1	22.3	6.165	97.5	36.4
21.397	47.3	8.5	11.168	72.5	22.5	6.089	98.1	36.7
21.088	47.8	8.8	11.02	73	22.8	6.015	98.6	37
20.886	48.2	9	10.874	73.6	23.1	5.941	99.1	37.3
20.586	48.7	9.3	10.778	73.9	23.3	5.869	99.7	37.6
20.29	49.3	9.6	10.636	74.5	23.6	5.798	100.2	37.9
20.096	49.6	9.8	10.542	74.8	23.8	5.728	100.8	38.2
19.809	50.2	10.1	10.404	75.4	24.1	5.658	101.3	38.5
19.526	50.7	10.4	10.312	75.7	24.3	5.59	101.8	38.8
19.34	51.1	10.6	10.177	76.3	24.6	5.522	102.4	39.1
19.065	51.6	10.9	10.088	76.6	24.8	5.456	102.9	39.4
18.884	52	11.1	9.956	77.2	25.1	5.39	103.4	39.7
18.616	52.5	11.4	9.869	77.5	25.3	5.326	104	40
18.352	53.1	11.7	9.741	78.1	25.6	5.262	104.5	40.3
18.179	53.4	11.9	9.614	78.6	25.9	5.199	105.1	40.6
17.503	54.9	12.7	9.53	79	26.1	5.137	105.6	40.9
17.339	55.2	12.9	9.407	79.5	26.4	5.076	106.2	41.2
17.095	55.8	13.2	9.325	79.9	26.6	4.995	106.9	41.6
16.856	56.3	13.5	9.205	80.4	26.9	4.936	107.4	41.9
16.698	56.7	13.7	9.086	81	27.2	4.877	108	42.2
16.465	57.2	14	9.007	81.3	27.4	4.82	108.5	42.5
16.312	57.6	14.2	8.891	81.9	27.7	4.763	109	42.8
16.085	58.1	14.5	8.815	82.2	27.9	4.688	109.8	43.2
15.935	58.5	14.7	8.702	82.8	28.2			

13. Program Parameter Listing

Programming

(4 Stage Controller)

P 1-9 Stage Programming

P1 = Stage Sensor
10= Sensor 1
02= Sensor 2
12= Average of Sensors 1&2

P2 = Stage Mode
1= Heat Mode
2= Cool Stir Mode
3= Cool Neg. Mode
4= Cool Neg. Tunnel Mode
5= Cool Tunnel Mode

P3 = Timer Status
0= Stage Not On Timer
1= Stage On Timer
2= Stage On Cool Timer

P4 = On Temperature (Max. On Point)
P5 = Off Temperature (Min. On Point)

P 20-29 Curtain Machine

P20 = Curtain Cycle time (min.)
P21 = Curtain Runtime (sec.)
P22 = Curtain Initial Runtime (sec.)
P23 = Unit 1 Degrees Above Target
P24 = Unit 2 Degrees Above Target
P25 = Tunnel "On" Temperature
P26 = Tunnel "Off" Temperature
P27 = Close Override (Degrees Below Target)

P 40-49 Hired Hand Network

P40 = Network Address
P41 = Software Version
P42 = Controller Setup

P 70-79 Timer Settings

P70 = Cool Timer Max. Percentage
P71 = Cool Timer Min. Percentage

PS Sensor Calibration

PS1 = Sensor 1
PS2 = Sensor 2
PS3 = Sensor 3

4501-5087 rev 8-04

14. Error Code Listing

Error Code	Description	Sensor 1 Error	Sensor 2 Error	Sensor 3 Error	Tunnel Error
E1	Sensor 1 Error	X			
E2	Sensor 2 Error		X		
E3	Sensor 1 & 2 Error	X	X		
E4	Sensor 3 Error			X	
E5	Sensor 1 & 3 Error	X		X	
E6	Sensor 2 & 3 Error		X	X	
E7	Sensor 1,2 & 3 Error	X	X	X	
E16	Tunnel Error				X
E17	Tunnel and Sensor 1 Error	X			X
E18	Tunnel and Sensor 2 Error		X		X
E19	Tunnel and Sensor 1 & 2 Error	X	X		X
E20	Tunnel and Sensor 3 Error			X	X
E21	Tunnel and Sensor 1 & 3 Error	X		X	X
E22	Tunnel and Sensor 2 & 3 Error		X	X	X
E23	Tunnel and Sensor 1,2 & 3 Error	X	X	X	X

14. Program Data Sheet

Farm Hand Four Stage

Use this Data Sheet to record your personal settings for the Farm Hand Four Stage. Copy this form as needed.

Target	
Timer %	

Status Switches	
Swx 1 Lock	On/Off
Swx 2 Unit	On-Fah./Off-Cel.
Swx 3 Timer	On-10/Off-5
Swx 4 Curtain	On-SS/Off-Avg.
Swx 5 Tunnel On	On/Off
Swx 6 Initiate	On-Stage/Off-Outside
Swx 7 House Style	On-Power/Off-Natural
Swx 8 Program	On-B/Off-A

Stages	Equipment	P4 On Point	P5 Off Point	P1 Sensors	P2 Mode	P3 Timer
1						
2						
3						
4						

P20 Curtain Cycle Time	Min.
P21 Curtain Runtime	Sec.
P22 Curtain Initial Runtime	Sec.
P23 Unit 1 DAT	
P24 Unit 2 DAT	
P25 Tunnel "On" Temp	
P26 Tunnel "Off" Temp	
P27 Close Override	

Network Address	P40	
Software Version	P41	
Controller Setup	P42	
Cool Timer Max. %	P70	
Cool Time Min. %	P71	

P1 Sensors

10=Sensor 1
02=Sensor 2
12=Avg. Sen 1&2

P2 Mode

1=Heat
2=Cool Stir
3=Cool Neg
4=Cool Neg. Tunnel
5=Cool Tunnel

P3 Timer

0=Off Timer
1=On Normal Timer
2=On Cool Timer

(Version 15 or above)

15. Curtain Movement Time (sec.) Vs. Distance (inches/cm.)

To find the distance moved, select the chart corresponding to a specific Motor Speed and Cabling Ratio.

NOTE: Cabling Ratio = First number is PT and second number is load.

Motor RPM	Cabling Ratio	Seconds	Inches	Centimeters
15	1 to 1	5	0.25	0.635
		10	0.50	1.27
		15	0.75	1.905
		30	1.5	3.81
		45	2.25	5.715
		60	3	7.652
	1 to 2	5	0.5	1.27
		10	1.0	2.54
		15	1.5	3.81
		30	3.0	7.62
		45	4.5	11.43
		60	6.0	15.24
	2 to 1	5	0.125	0.3175
		10	0.25	0.635
		15	0.375	0.9525
		30	0.75	1.905
		45	1.125	2.875
		60	1.5	3.81
30	1 to 1	5	0.5	1.27
		10	1.0	2.54
		15	1.5	3.81
		30	3.0	7.62
		45	45.5	11.43
		60	6.0	15.24
	1 to 2	5	1	2.54
		10	2	5.08
		15	3	7.62
		30	6	15.24
		45	9	22.86
		60	12	30.48
	2 to 1	5	0.25	0.635
		10	0.50	1.27
		15	0.75	1.905
		30	1.5	3.81
		45	2.25	5.715
		60	3	7.652
60	1 to 1	5	1	2.54
		10	2	5.08
		15	3	7.62
		30	6	15.24
		45	9	22.86
		60	12	30.48
	1 to 2	5	2	5.08
		10	4	10.16
		15	6	15.24
		30	12	30.48
		45	18	45.72
		60	24	60.96
	2 to 1	5	0.5	1.27
		10	1.0	2.54
		15	1.5	3.81
		30	3.0	7.62
		45	45.5	11.43
		60	6.0	15.24